



THERMOPLASTIC COMPOSITES
RESEARCH CENTER

FibReLoop

UNIVERSITY
OF TWENTE.



Funded by
the European Union

PACKING STRESS OF RECYCLED LONG-FIBER THERMOPLASTIC COMPOSITES: MITIGATING HETEROGENEITY EFFECTS

Paul Ceralde | 01 July 2026

TABLE OF CONTENTS

1 Introduction: Recycling TPCs and Preforming to Plates

2 Packing stress: Influence of Specimen Dimensions

3 Packing stress: Influence of Preforming Conditions

4 Outlook: Structural Analysis, Fiber-fiber Interactions



PREFORMING OF LONG-FIBER rTPC

RECYCLED LONG-FIBER Thermoplastic Composites

Low-shear mixing: preserving fiber length

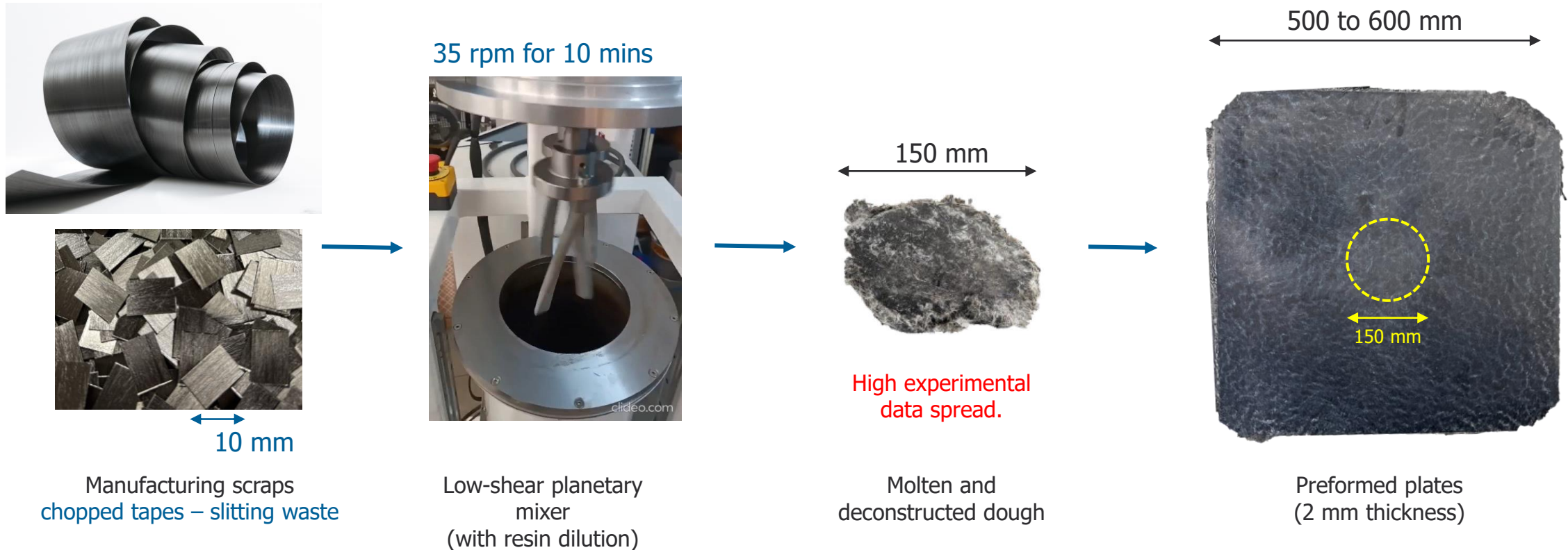

[1] G. A. Vincent. Recycling of Thermoplastic Composite Laminates: The role of processing. PhD Thesis at University of Twente, 2020.

[2] F.F. Visser. Optimised Matrix and Fibre Treatment for High Performance Thermoplastic Composites recycling. PhD Thesis at University of Twente, In Progress.

WHY PRESS THE DOUGHS?

Reducing stochastic effects and structural complexity

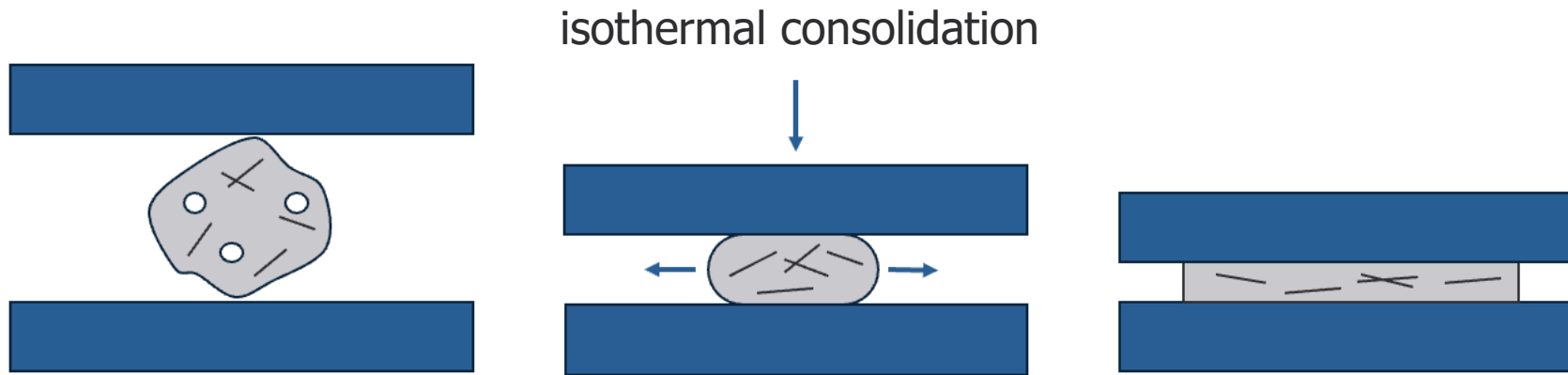

↕ Planar orientation

∖ Additional fiber dispersion

🔧 Production-ready format

- Material more repeatable
- Property more predictable

[3] O. Guiraud, P.J.J. Dumont, & L. Orgéas, "How to Prepare SMC and BMC-like Compounds to Perform Relevant Rheological Experiments?". *Applied Composite Materials*, 20: 157–169, 2013.

PRE-FORMING PROCESS

Free Pressing vs Full Consolidation

⊕ Planar orientation ↘ Additional fiber dispersion

Free Pressing

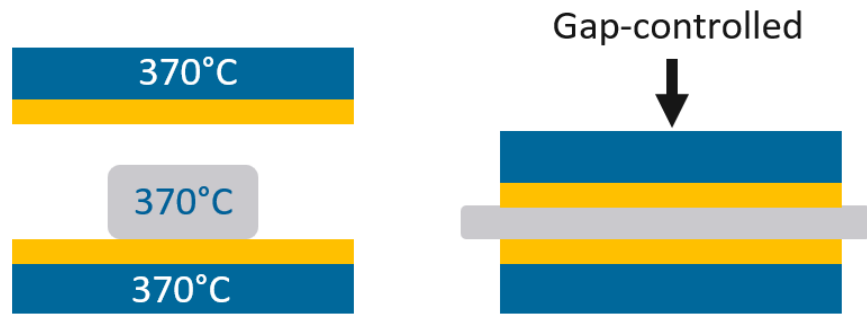

For optimum fiber freedom

Full Consolidation

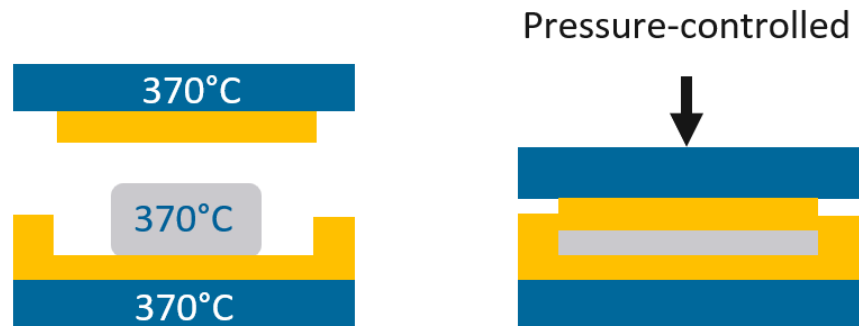

For optimum void reduction

HOW TO USE THE PLATES?

 Production-ready format

Press-Forming: High Throughput Production

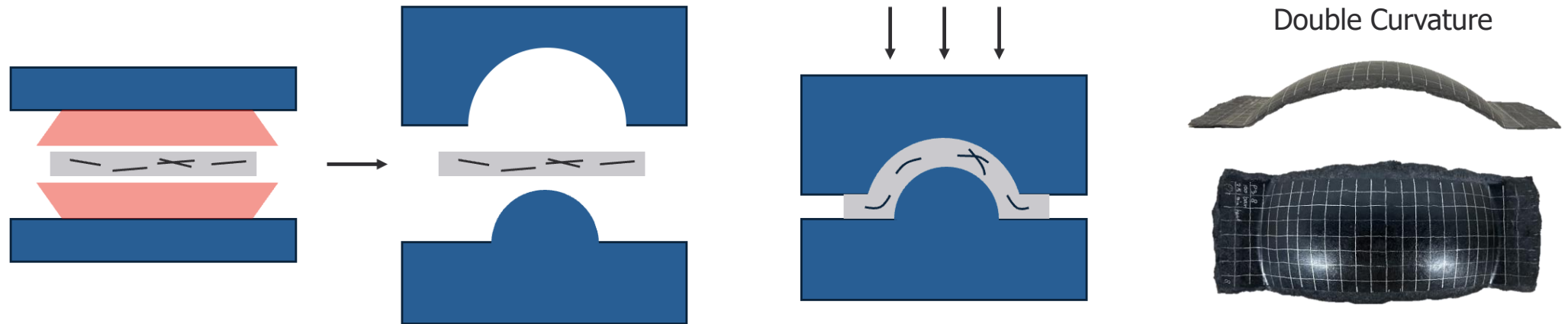

0 Fibre-fibre Interactions

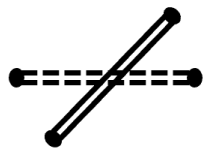

1 Through-thickness Behavior

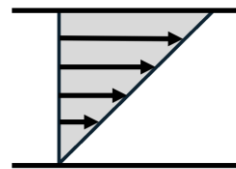

2 In-plane Behavior

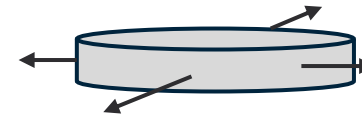

3 Squeeze Flow (1D)

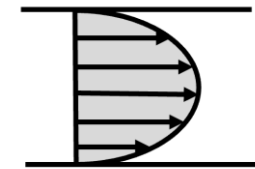

CONCENTRATED FIBER SUSPENSIONS

Packing behavior: a glimpse to fibre assembly

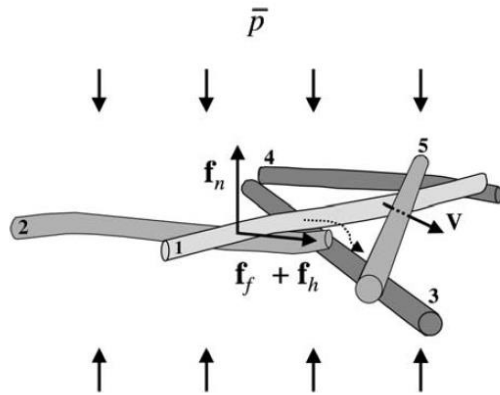

Fiber-fiber interactions in compression

f_n - normal packing force

f_f - friction force

f_h - hydrodynamic lubrication force

v - velocity difference between fibres

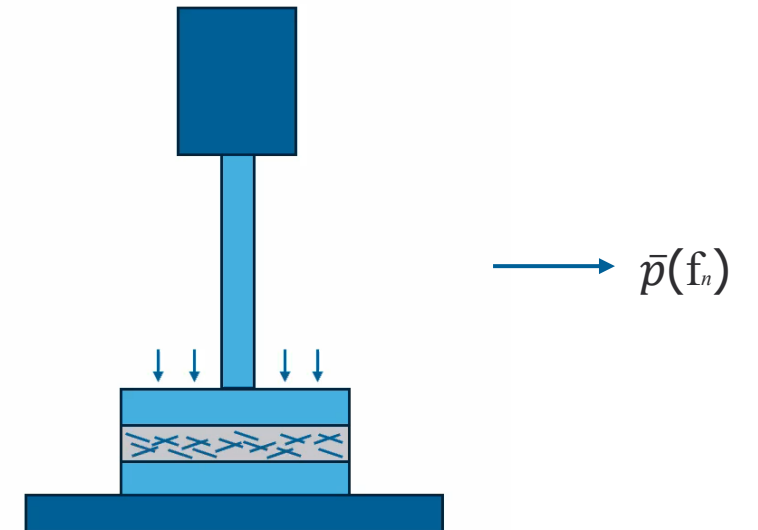

Compaction experiment
(low speed: 1 micron/s)

$$v = 0$$

[4] C. Servais, A. Luciani, and J.-A. E. Månson, "Squeeze flow of concentrated long fibre suspensions: experiments and model," *Journal of Non-Newtonian Fluid Mechanics*, vol. 104, no. 2–3, pp. 165–184, Jun. 2002

OBJECTIVE

Can we measure consistent material response?

Packing stress of recycled long fiber thermoplastic composites from low shear mixing:

- Influence of specimen dimensions
- Influence of pre-forming conditions

INPUT MATERIALS

Properties and preforming method

	APC - AS4D/PEKK-FC
Original Structure	Chopped UD
Fibre length	12 mm
Fiber content (vol)	0.59 (v/v) → 0.20 (v/v)



Chopped C/PEKK-FC UD tapes
(APC - Syensqo)



INFLUENCE OF SPECIMEN DIMENSIONS

SPECIMEN MEASUREMENTS

Thickness, basis weight and apparent density

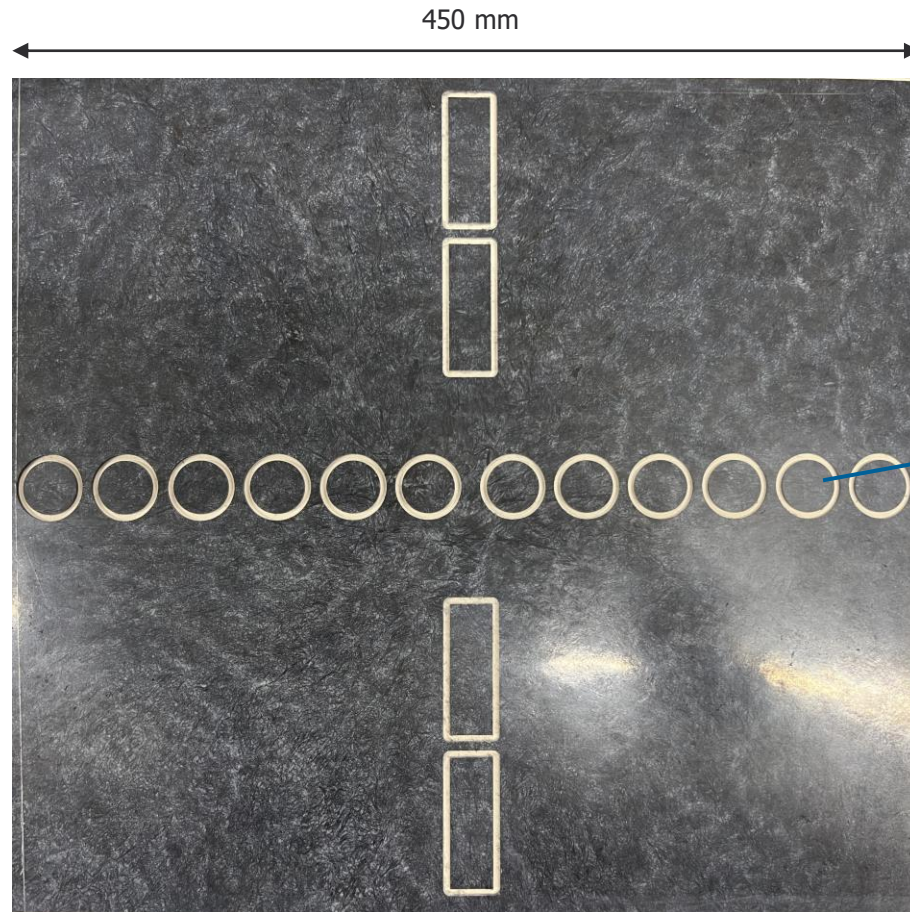

APC-25FP: 25 mm
APC-30FP: 30 mm

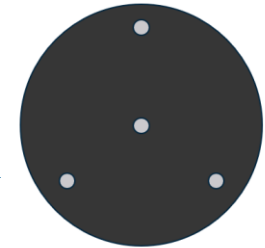

Thickness: average of four values
from ball-point probe

Weight: precision scale
(dried for > 48hrs)

Apparent Density (ρ_a): $\frac{\text{weight}}{\text{thickness} \times \text{disc area}}$

[3] O. Guiraud, P.J.J. Dumont, & L. Orgéas, "How to Prepare SMC and BMC-like Compounds to Perform Relevant Rheological Experiments?". *Applied Composite Materials*, 20: 157–169, 2013.

COMPACTION EXPERIMENTS

Packing stress measurements

T = 20°C

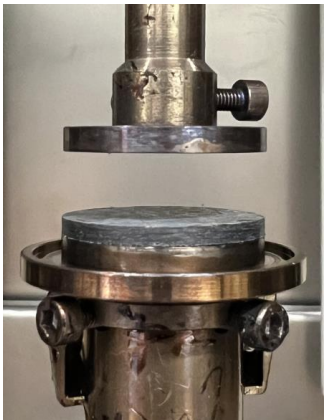

T = 370°C



T = 370°C



Specimen can lift up to > 2x original thickness

Overlay of relaxation curves

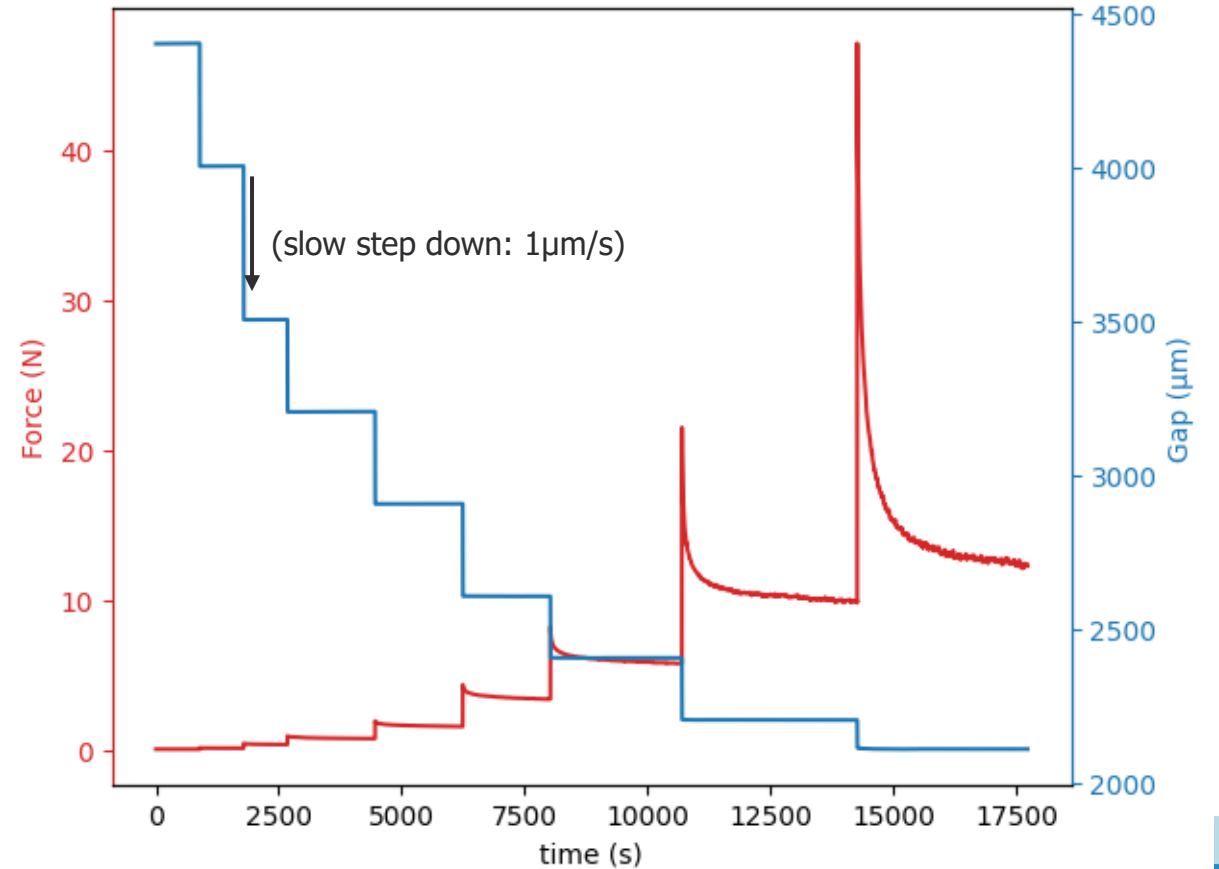

COMPACTION EXPERIMENTS

Packing stress measurements

$$P = \frac{\text{relaxed force}}{\text{contact area}}$$

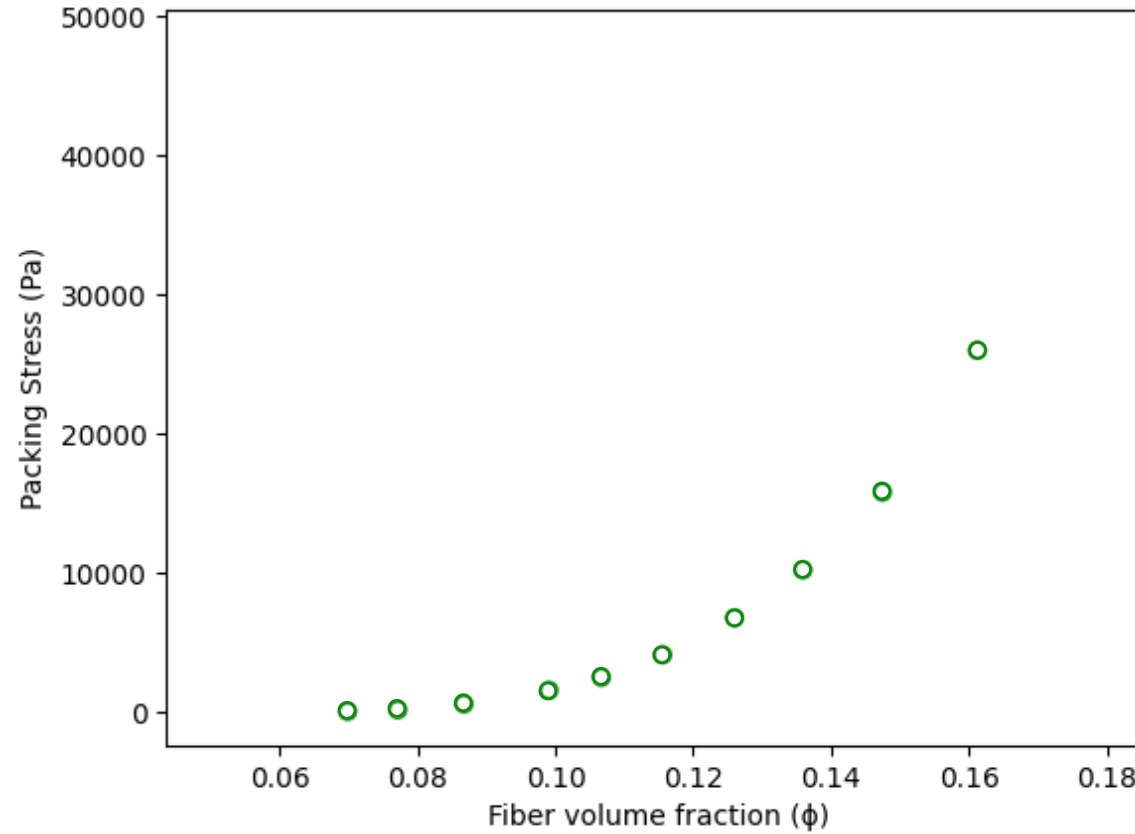

$$\phi = \frac{\text{fibre volume}}{\text{specimen area} \times \text{gap}}$$

COMPACTION EXPERIMENTS

Packing stress measurements (log-log plot)

$$\bar{p} = kE(\phi^n - \phi_0^n)$$

k – fitting coefficient
 n – power law index

E – fiber elastic modulus
 ϕ_0 – unpacked state

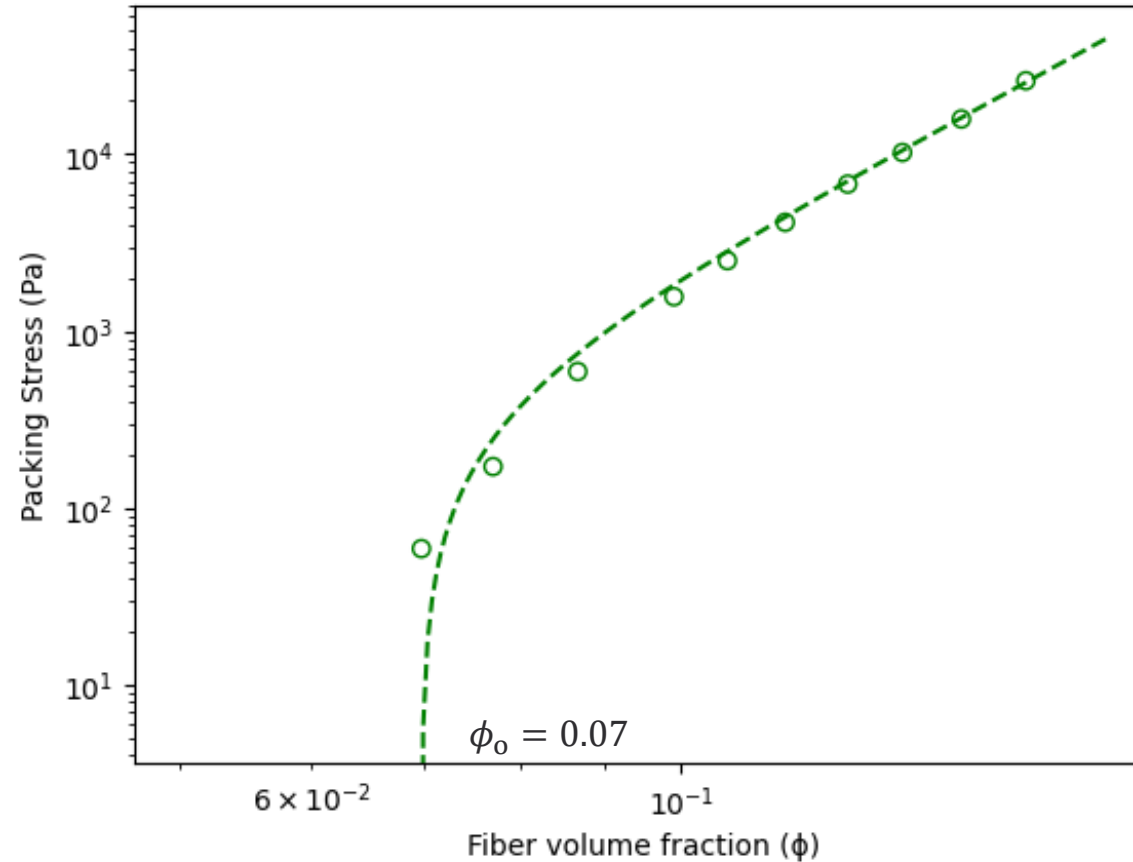

[5] S. Toll, "Packing mechanics of fiber reinforcements," *Polymer Engineering & Sci*, vol. 38, no. 8, pp. 1337–1350, Aug. 1998

Power law index (n)

$$P = kE(\phi^n - \phi_0^n)$$

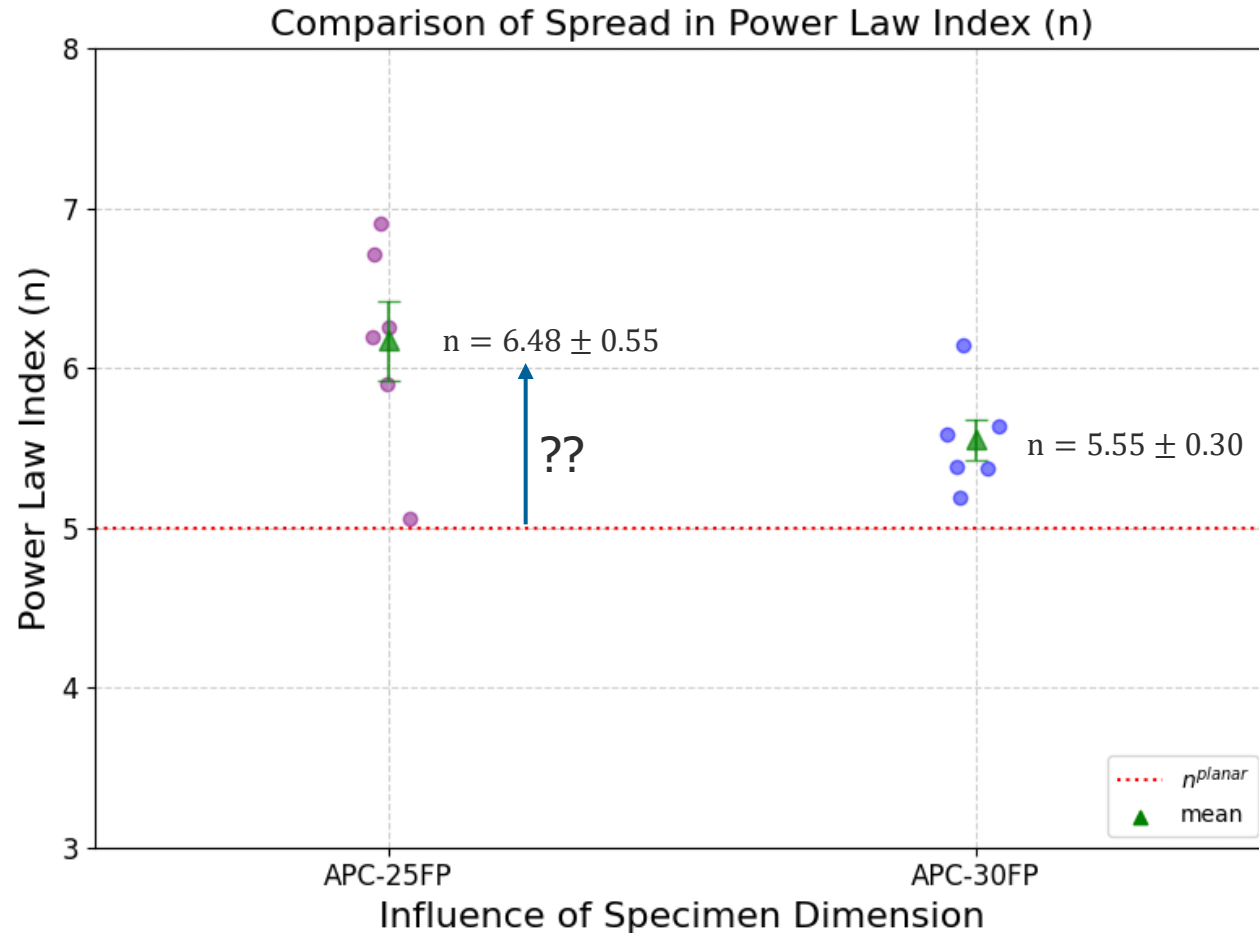

n varies with reinforcement assembly

assembly	n
3D fiber wads [5] (wool)	3
2D fiber mat [5] (GF)	5
2D fiber mat [6] (CF)	4.8 / 5.2
Fiber bundles [7] (GF)	<5
UD fiber beds [8] (CF)	>7
Woven fabric [8] (CF)	>7

- [6] A. C. Caba, A. C. Loos, and R. C. Batra, "Fiber-fiber interactions in carbon mat thermoplastics," *Composites Part A: Applied Science and Manufacturing*, vol. 38, no. 2, pp. 469–483, Feb. 2007
- [7] C. Servais, V. Michaud, and J. E. Månson, "The packing stress of impregnated fiber mats," *Polymer Composites*, vol. 22, no. 2, pp. 298–311, Apr. 2001, doi: 10.1002/pc.10539.
- [8] T. G. Gutowski, J. Kingery, and D. Boucher, SPE ANTEC Technical Papers, 32, 1316 (1986).

Power law index (n)

$$P = kE(\phi^n - \phi_0^n)$$

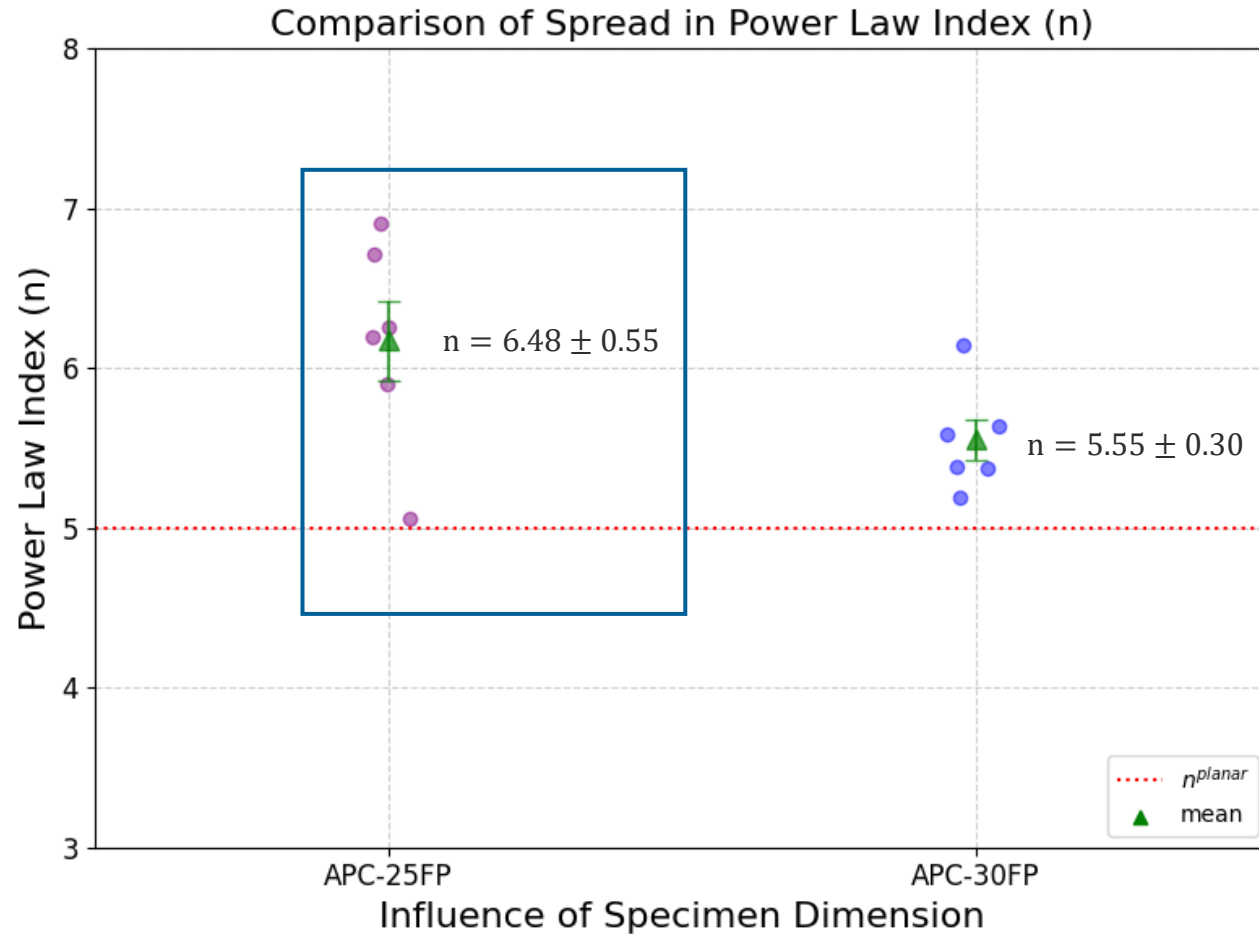

lofting → drifting
measurement inaccuracy

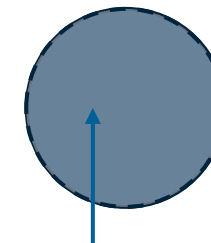

contact area not consistent

plate ($\phi 25$ mm)
specimen ($\phi 25$ mm)

Power law index (n)

$$P = kE(\phi^n - \phi_0^n)$$

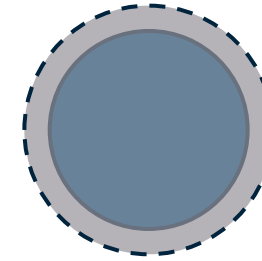
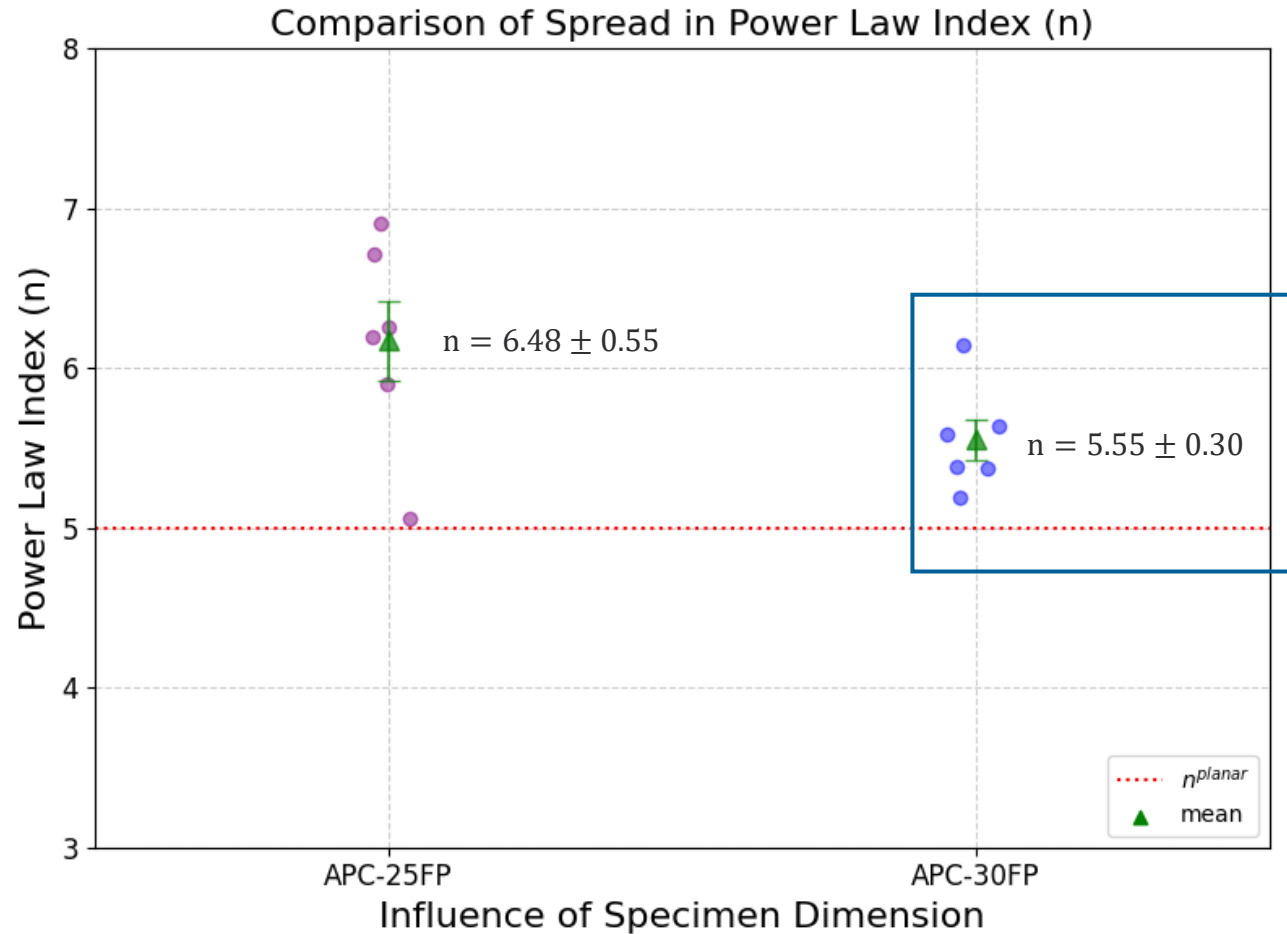



plate ($\phi 25$ mm)
specimen ($\phi 30$ mm)

- Data makes more sense
- Data is more consistent



INFLUENCE OF PREFORMING CONDITIONS

PRE-FORMING CONDITIONS

Free Pressing (FP) vs Full Consolidation (FC)



[9] Cilley, E., Roylance, D., and Schneider, N., "Methods of Fiber and Void Measurement in Graphite/Epoxy Composites". Composite Materials: Testing and Design (3rd Conference), ASTM STP 546, American Society for Testing Materials, 1974, pp. 237-249.

PROPERTY VARIABILITY

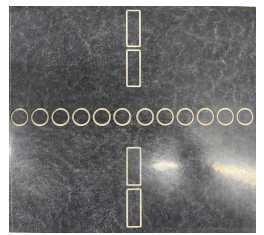

Free Pressing (FP) vs Full Consolidation (FC)

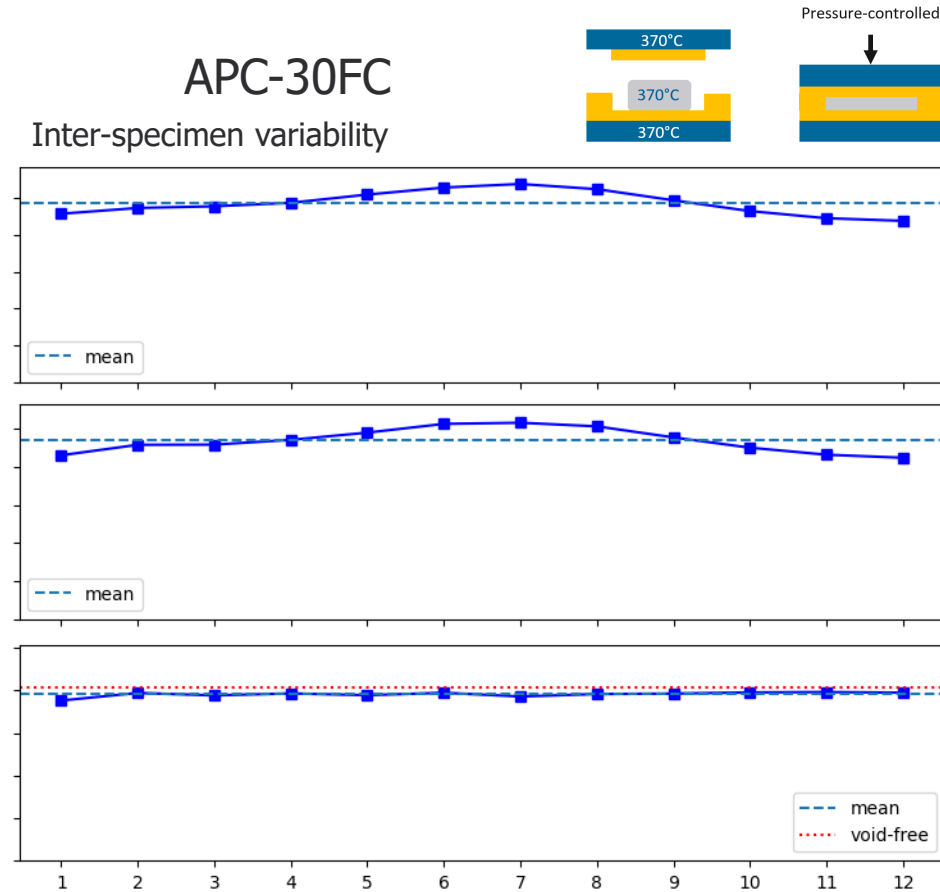
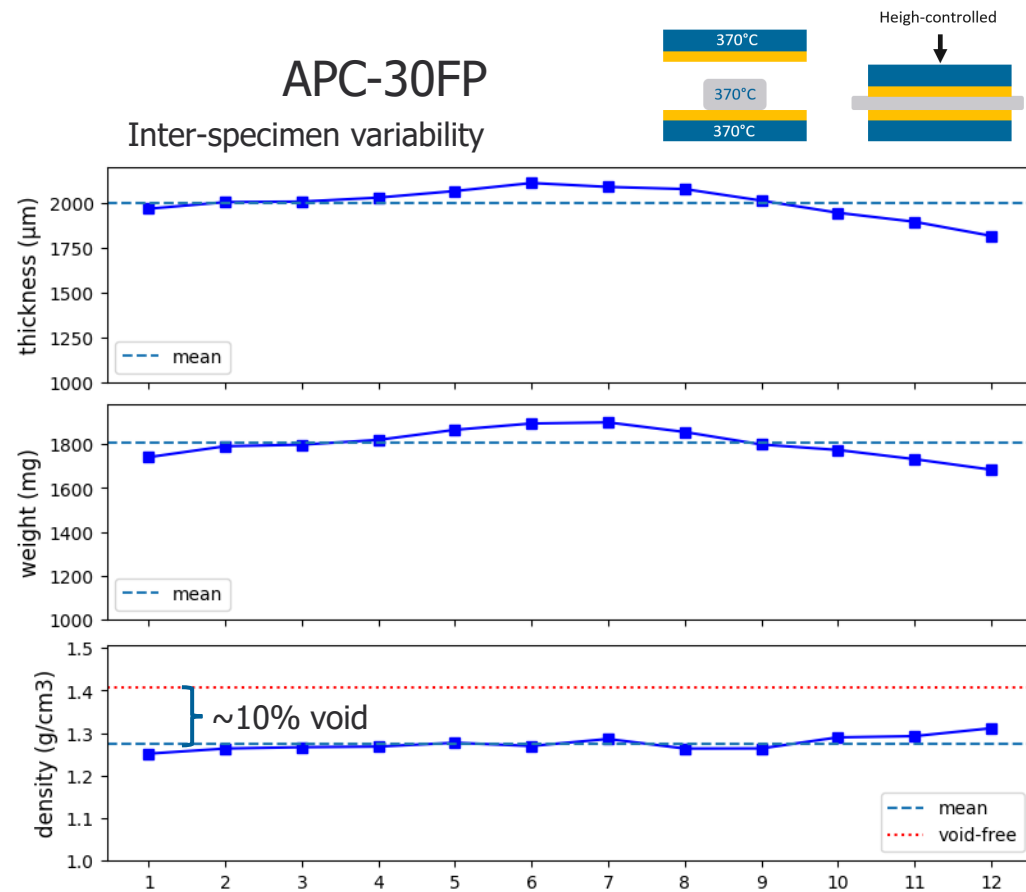

[9] Cillee, E., Roylance, D., and Schneider, N., "Methods of Fiber and Void Measurement in Graphite/Epoxy Composites". Composite Materials: Testing and Design (3rd Conference), ASTM STP 546, American Society for Testing Materials, 1974, pp. 237-249.

CHANGE OF SLOPE (KNEE) OBSERVED

What could be causing it?

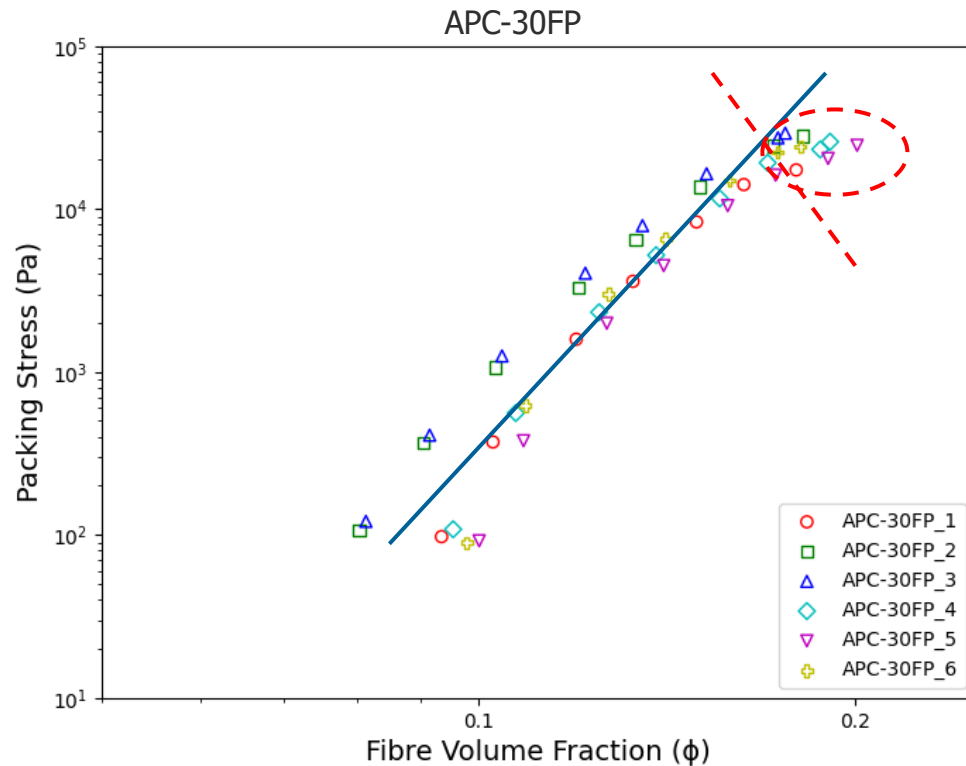

Change in slope was also observed in CMT at 2 MPa [6]
vs 40 kPa (in this study)

*Power-law fitting performed below knee

[6] A. C. Caba, A. C. Loos, and R. C. Batra, "Fiber-fiber interactions in carbon mat thermoplastics," *Composites Part A: Applied Science and Manufacturing*, vol. 38, no. 2, pp. 469-483, Feb. 2007

ON KNEE BEHAVIOR

Free Pressing (FP) vs Full Consolidation (FC)

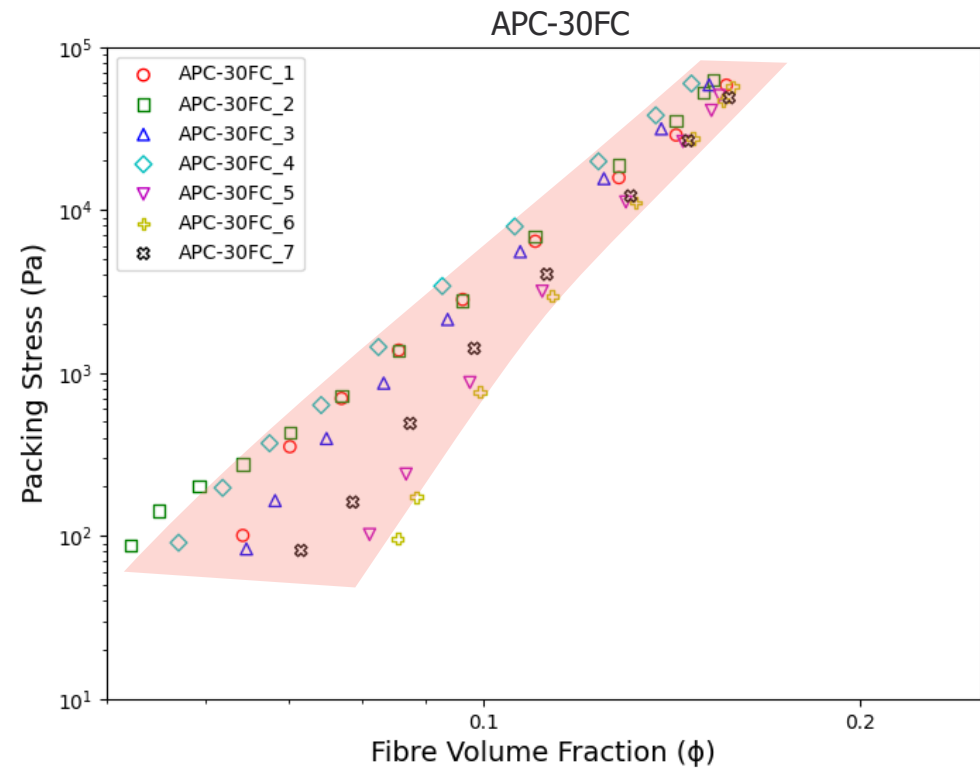
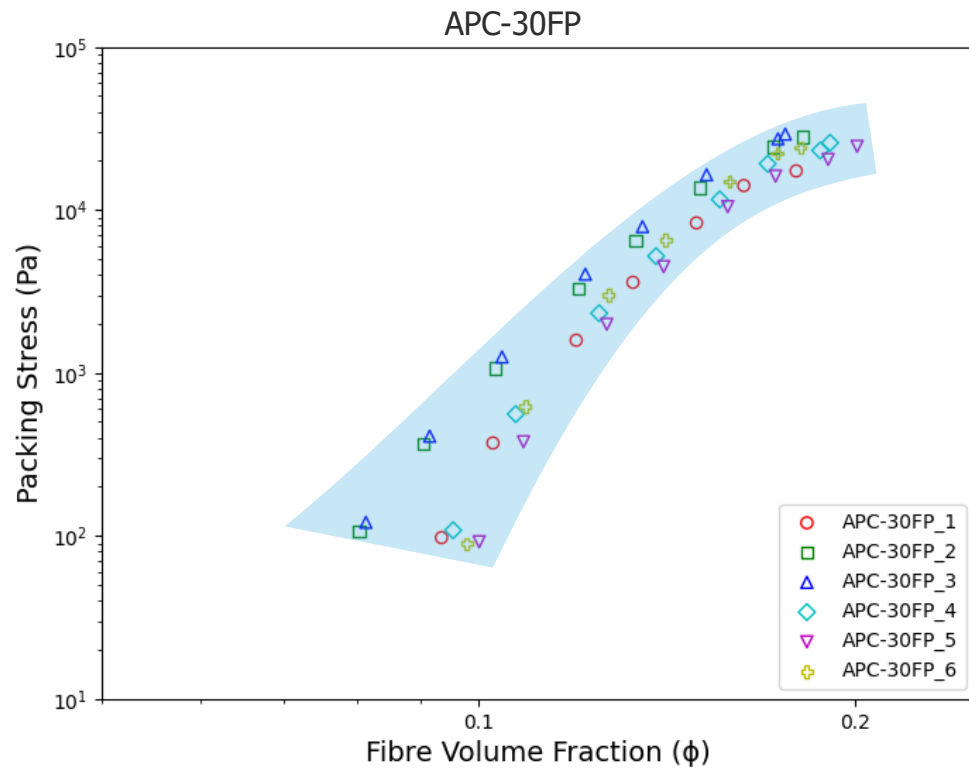

ON KNEE BEHAVIOR

Free Pressing (FP) vs Full Consolidation (FC)

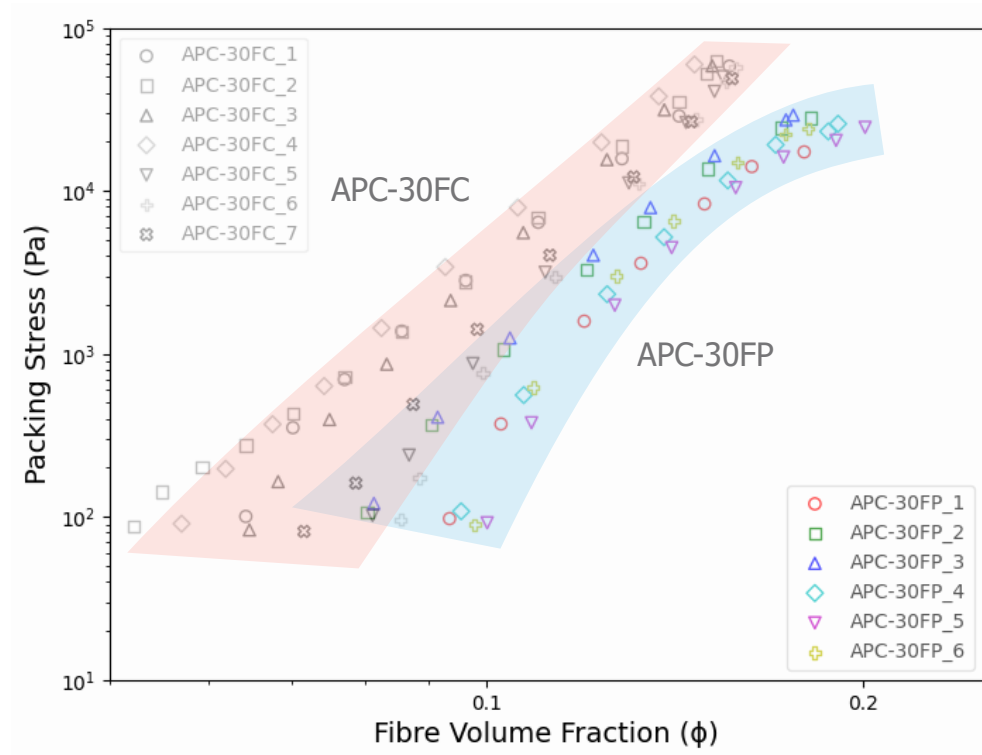

Knee is not observed in fully consolidated (FC) plates

$$\text{Void}_{FC} \sim 1\%$$

$$\text{Void}_{FP} \sim 10\%$$

Power law index (n)

$$P = kE(\phi^n - \phi_0^n)$$

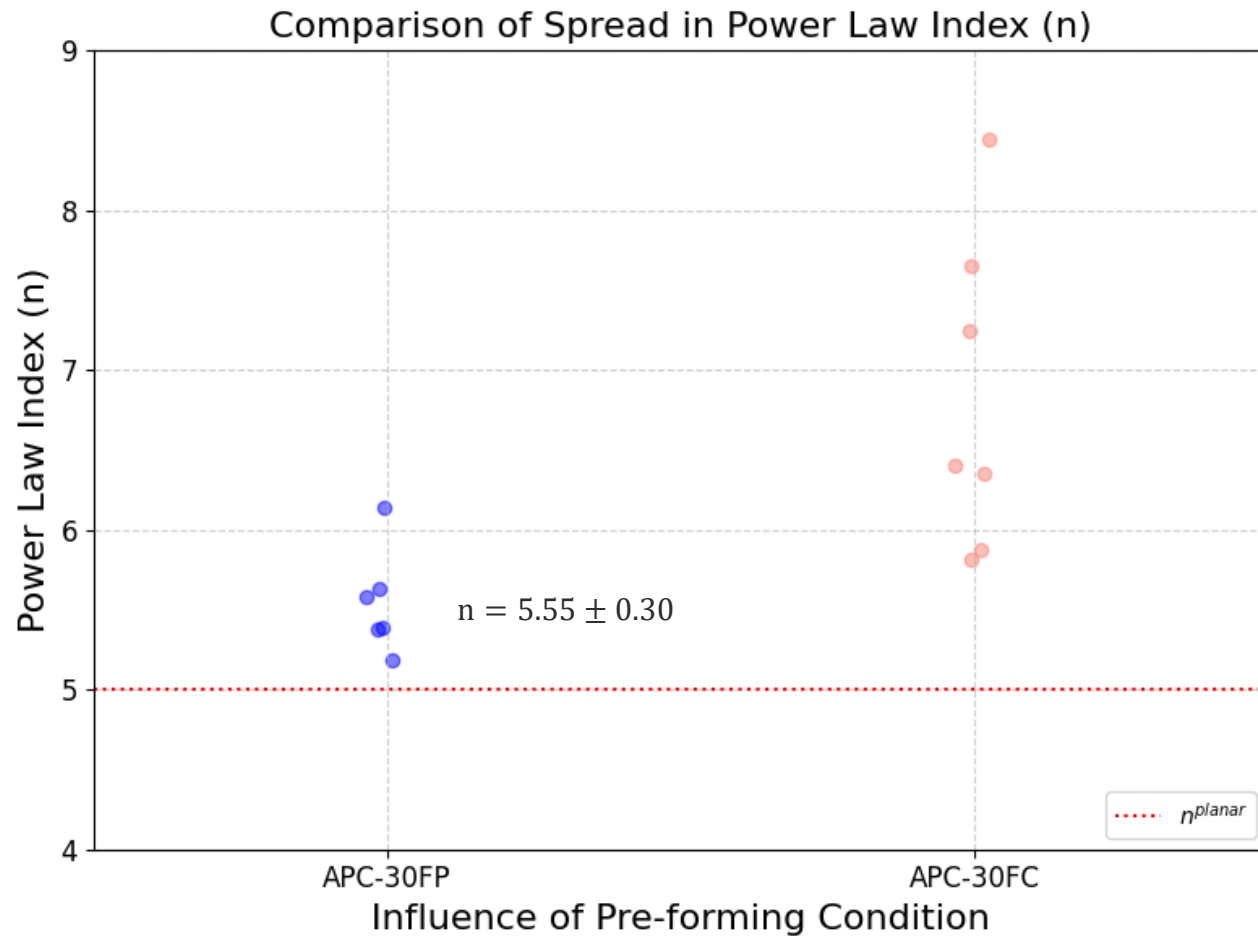

Specimen sampling location:

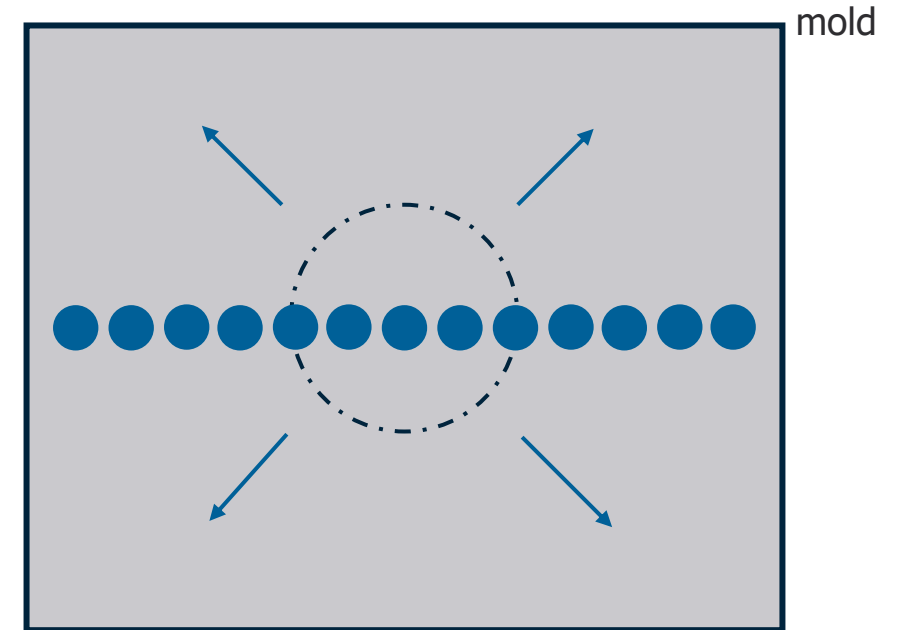

○ molten dough

● machined specimen

Power law index (n)

$$P = kE(\phi^n - \phi_0^n)$$

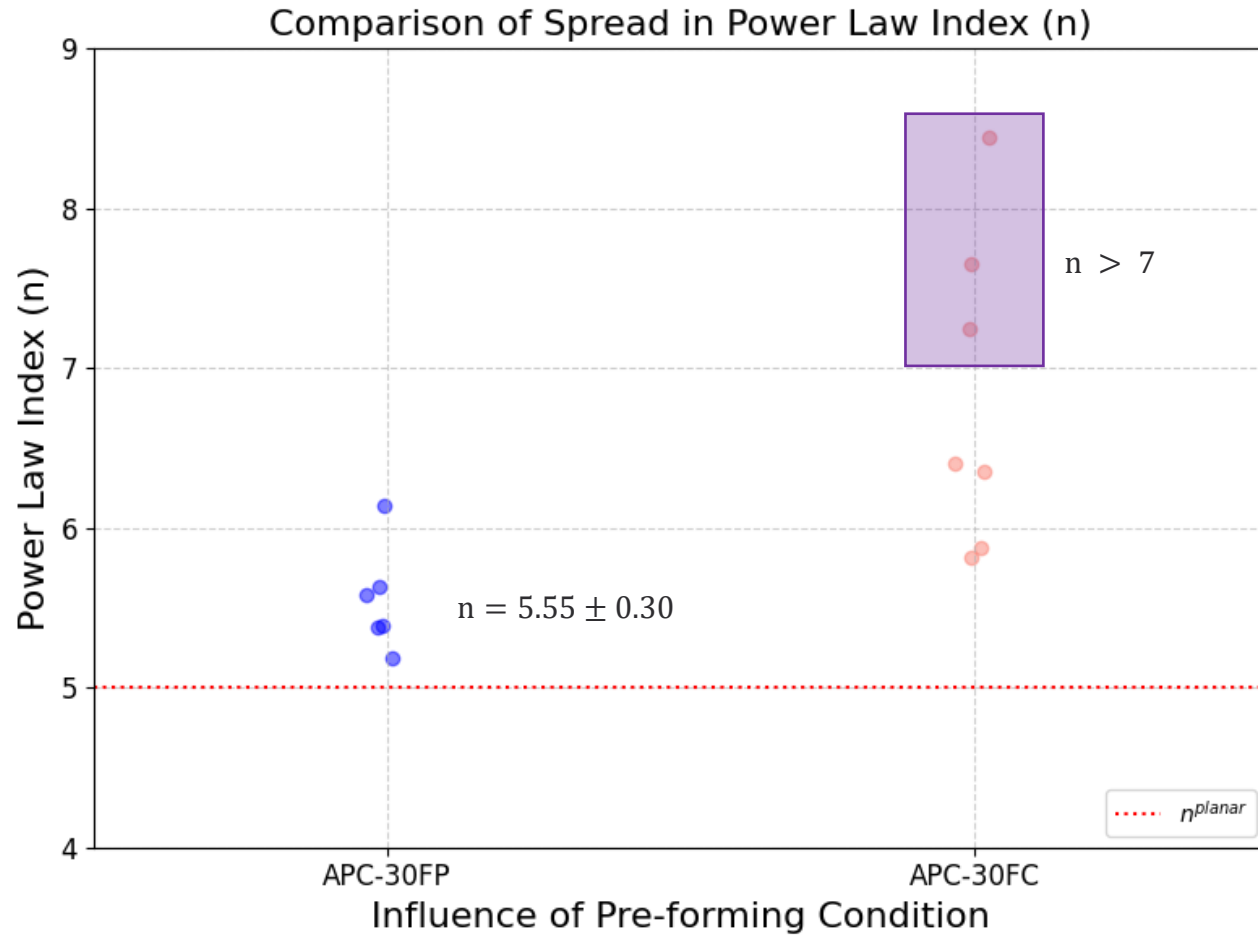

Specimen sampling location:

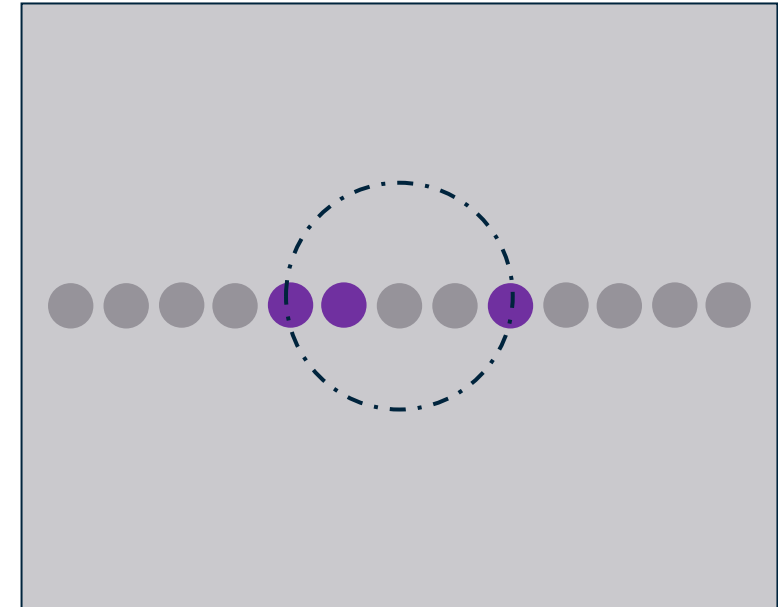

- molten dough
- low flow length

Power law index (n)

$$P = kE(\phi^n - \phi_0^n)$$

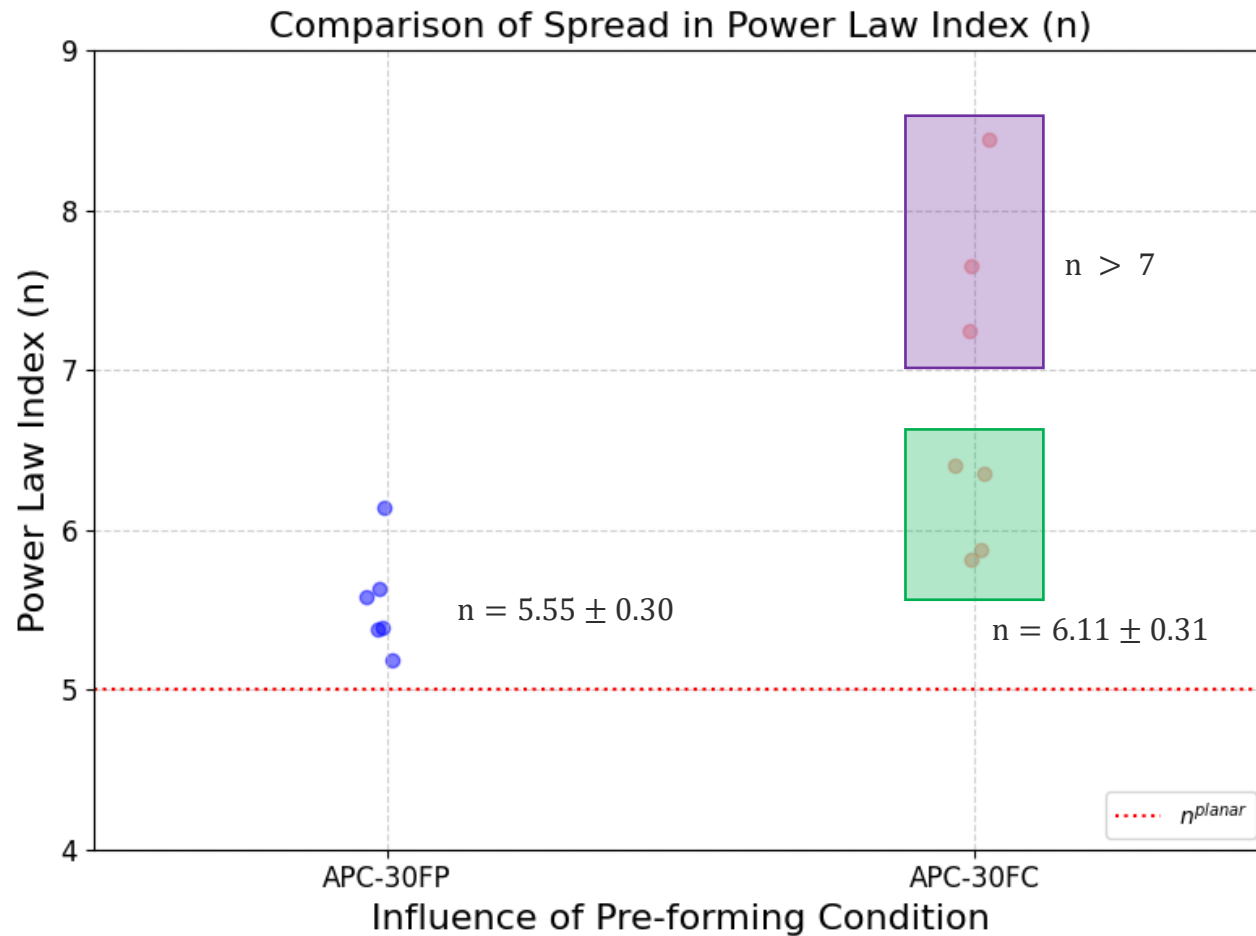

Specimen sampling location:

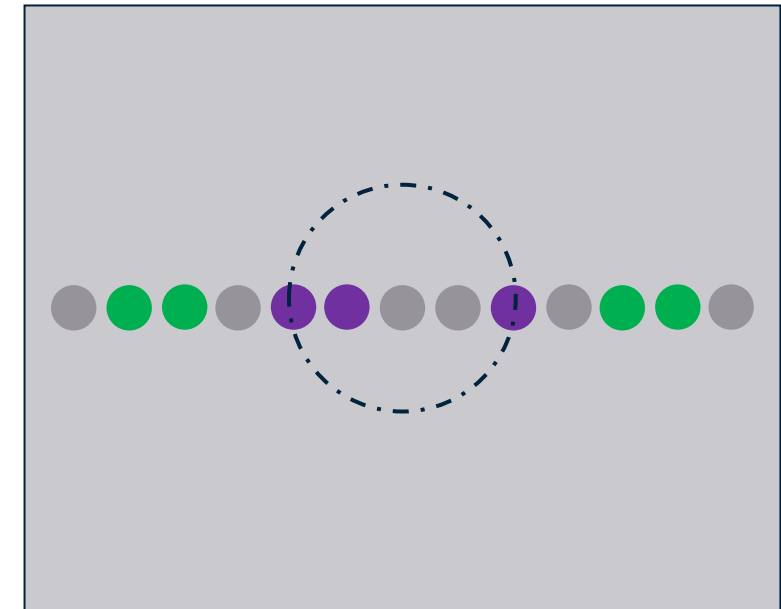

- molten dough
- low flow length
- high flow length
- untested specimen

Unpacked state (ϕ_0)

$$P = kE(\phi^n - \phi_0^n)$$

For a fiber assembly:



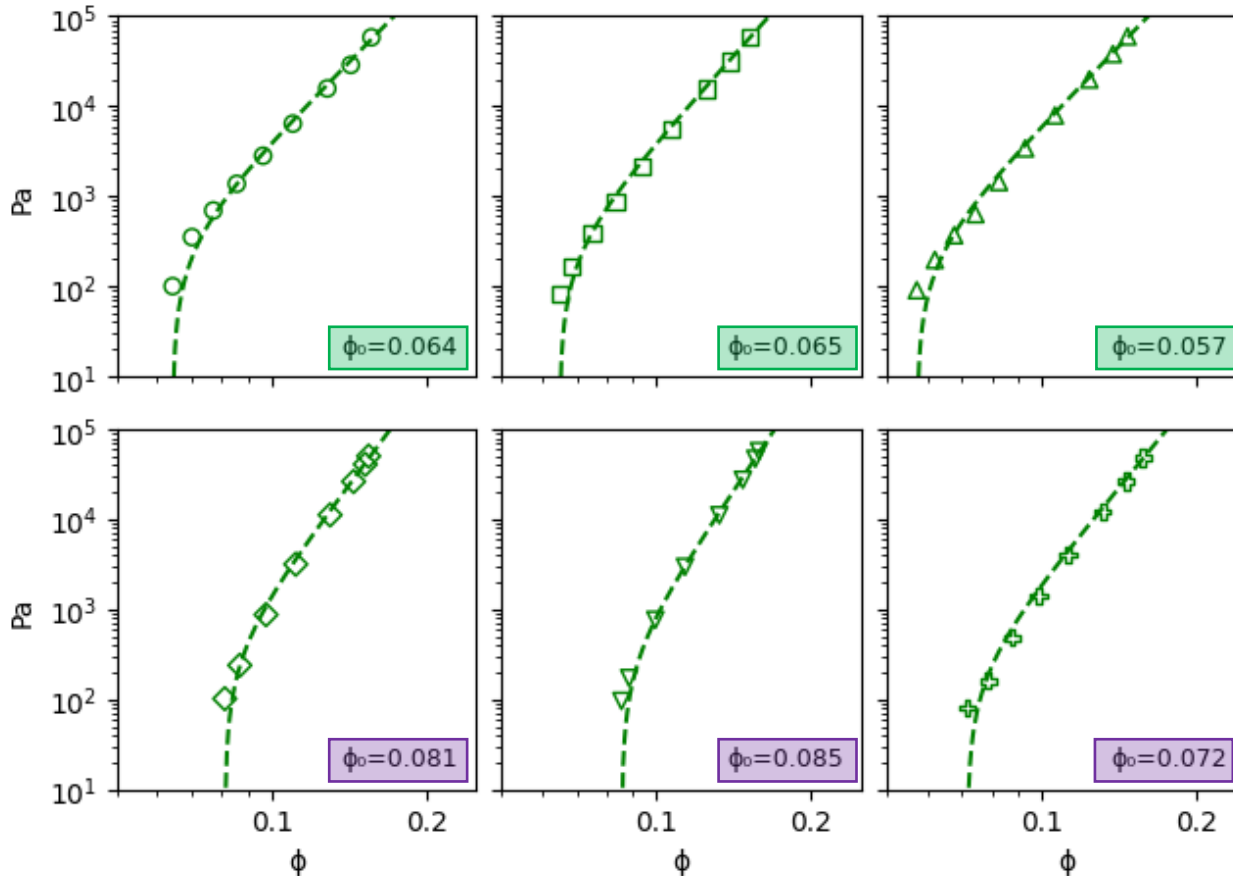

$\downarrow \phi_0$ \uparrow unpacking volume \uparrow fiber dispersion

Log-log plot of Coupled Offset Power Law fitting

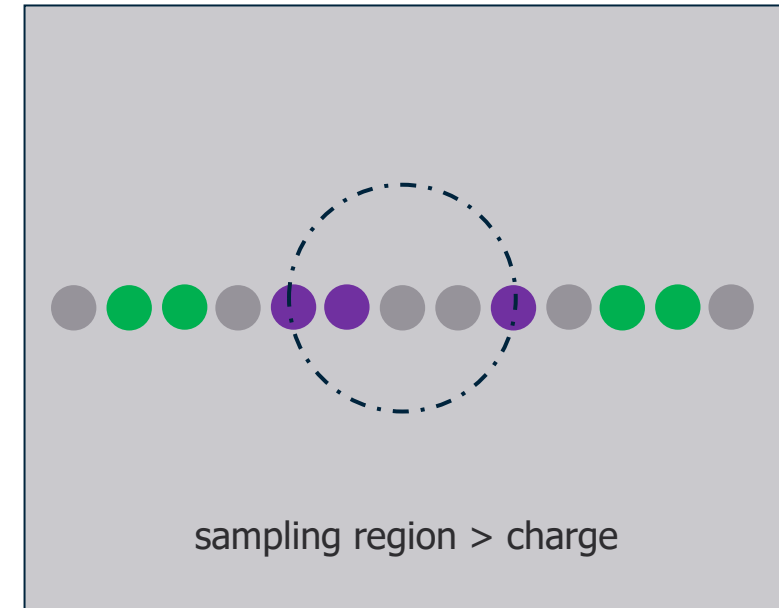

Specimen sampling location:



-  molten dough
-  low flow length (low fiber dispersion)
-  high flow length (high fiber dispersion)
-  untested specimen

CONCLUSIONS

- Specimen dimension (SD) with reference to plate dimension (PD) matters.
 - SD = PD: Can cause measurement errors due to drifting.
 - SD > PD: Can make response more consistent.
- Free pressing (FP) vs Full consolidation (FC):
 - FP: high void content (~10%) | FC: low void content (~1%)
 - FP: knee observed at ~40 kPa (limits useful data)
 - FC: material heterogeneity

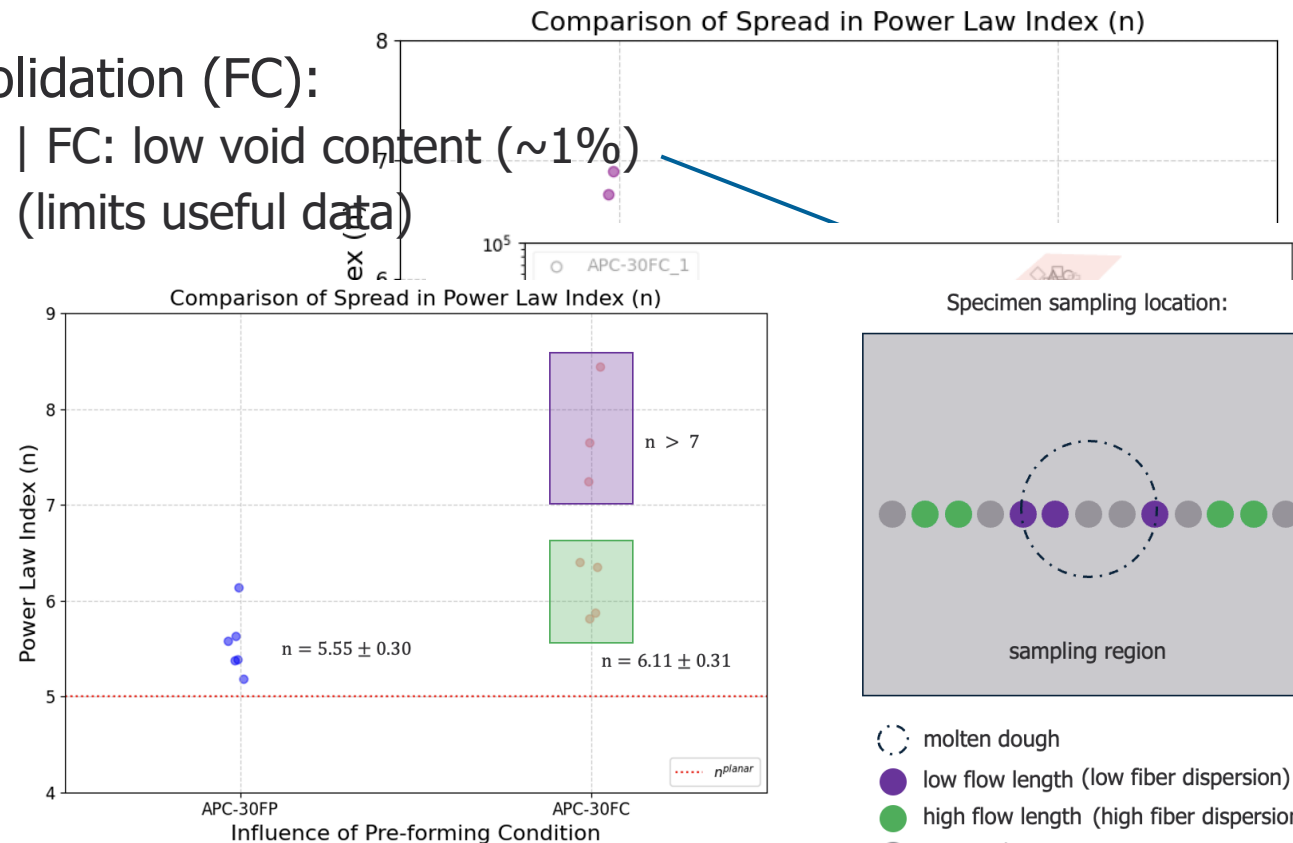
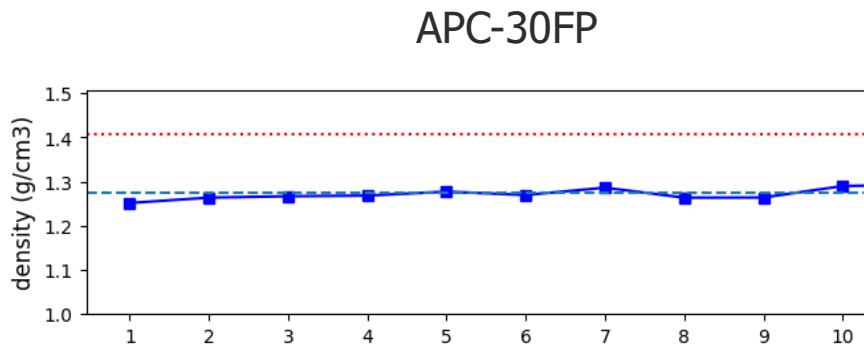

FUTURE WORK

- Analyze fibre structure using microscopy and micro-CT (regions of heterogeneity)
- Improve experimental setup:
 - Larger specimen dimensions (10-mm fiber length vs 25-mm diameter AOI)
 - Measure more points at high-stress regions (TA HR20: 50N force limit)
- Characterize fiber-fiber interactions in recycled carbon fiber (rCF) from low-shear mixing

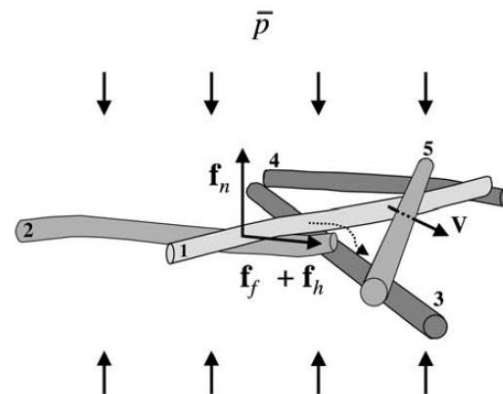

f_n - normal packing force ✓

f_f - friction force

f_h - hydrodynamic lubrication force

v - velocity difference between fibres

THANK YOU!

The research leading to these results has been performed within the framework of the FibReLoop project and has received funding from the European Union Horizon Europe research and innovation programme under the Marie Skłodowska-Curie (MSCA) grant agreement No 101169071.

Reach out to me here:

paul.ceralde@utwente.nl

Connect with me:





FOR Q&A

DIFFERENT TYPES OF FIBER SUSPENSIONS

Concentrated Regime

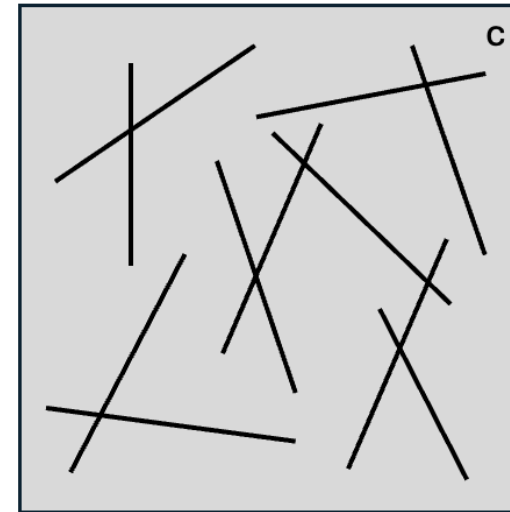
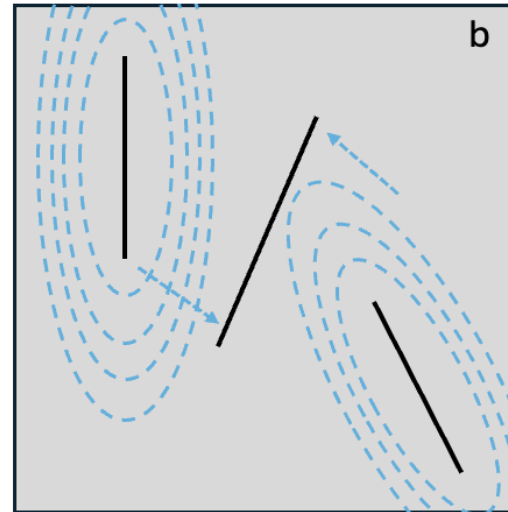
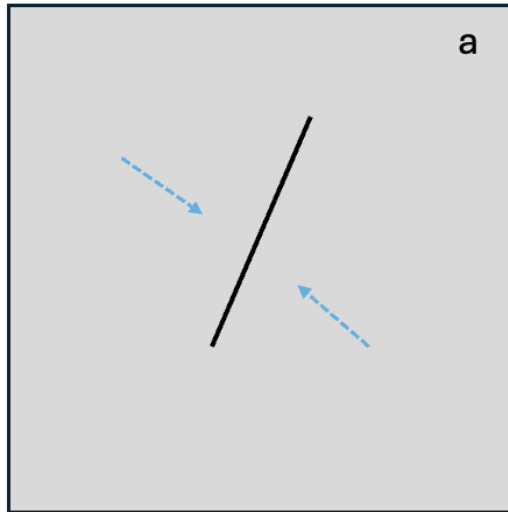

(a) diluted regime: fibers do not influence each other.

(b) semi-diluted regime: fibers influence each other, but do not touch.

(c) concentrated regime: fibers interact with each other via contact forces. **We are here.**

} Hydrodynamic interactions

[5] S. Toll and J.-A. E. Månson, "Dynamics of a planar concentrated fiber suspension with non-hydrodynamic interaction," *Journal of Rheology*, vol. 38, no. 4, pp. 985–997, Jul. 1994

COMPACTION EXPERIMENTS

Packing stress measurements

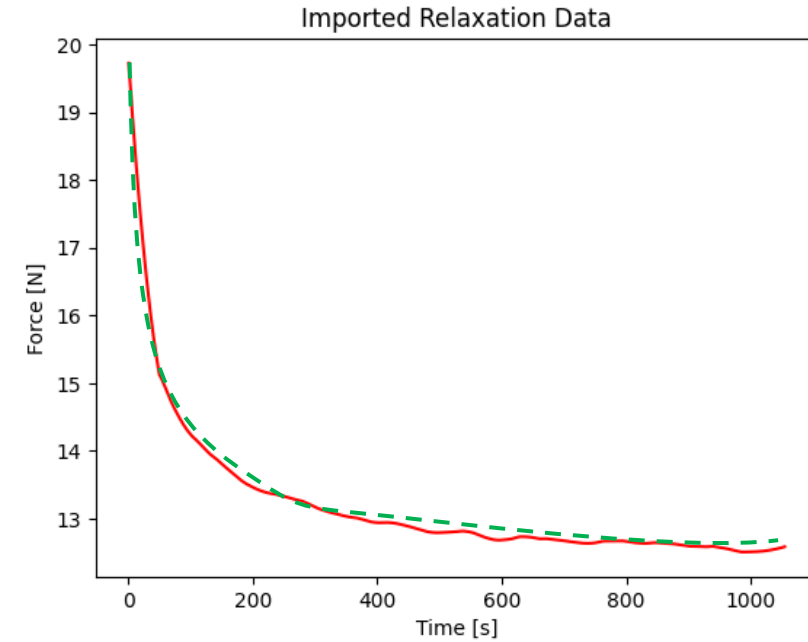
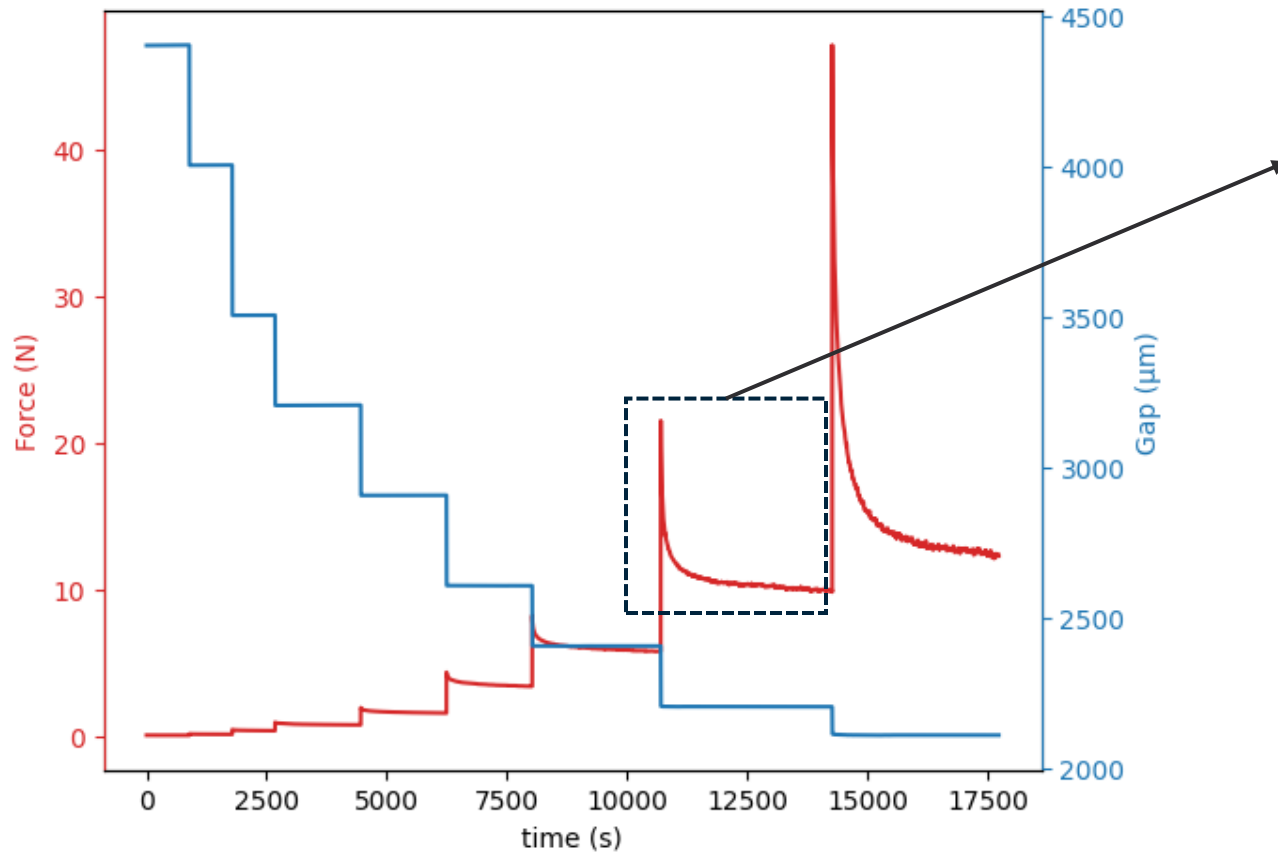

$$F = Ae^{\frac{-t}{\tau}} + F_o$$

↓
Relaxed force

COMPACTION EXPERIMENTS

Packing stress measurements

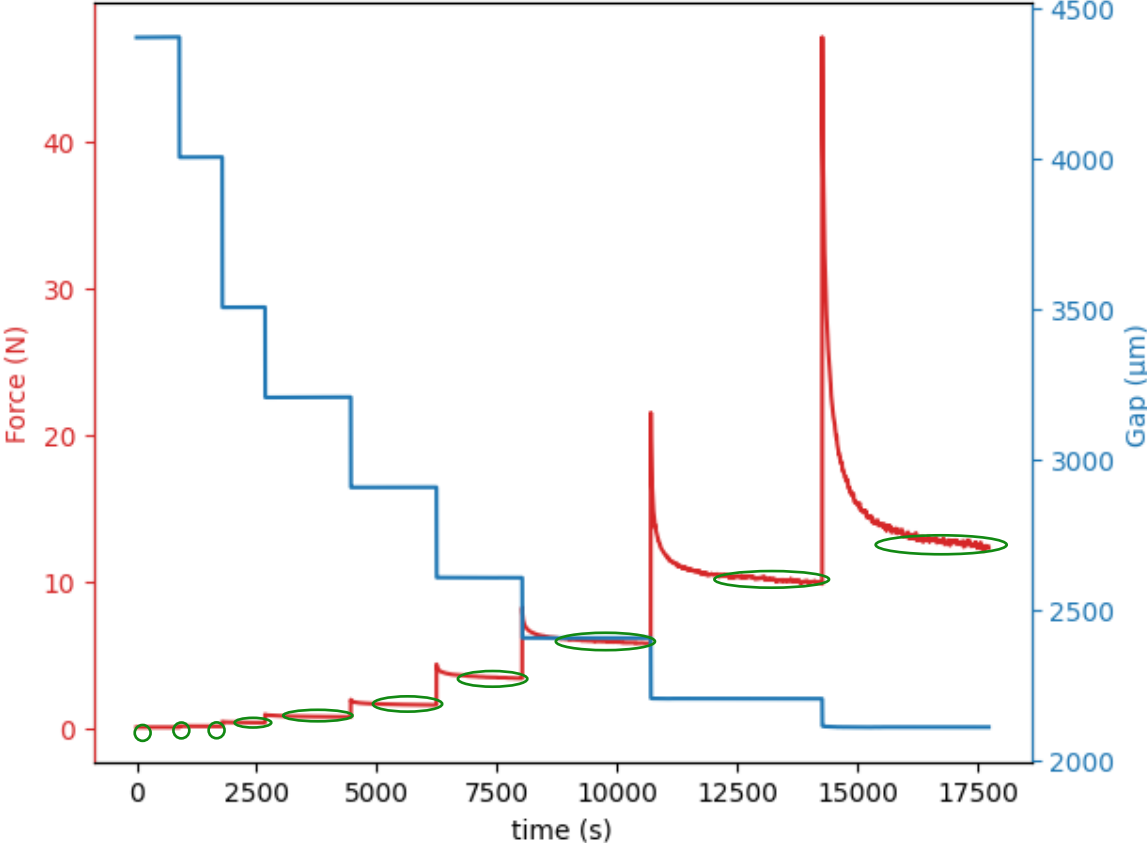

Relaxed force as a function of gap

COMPACTION EXPERIMENTS

Packing stress measurements

$$P = \frac{\text{relaxed force}}{\text{contact area}}$$

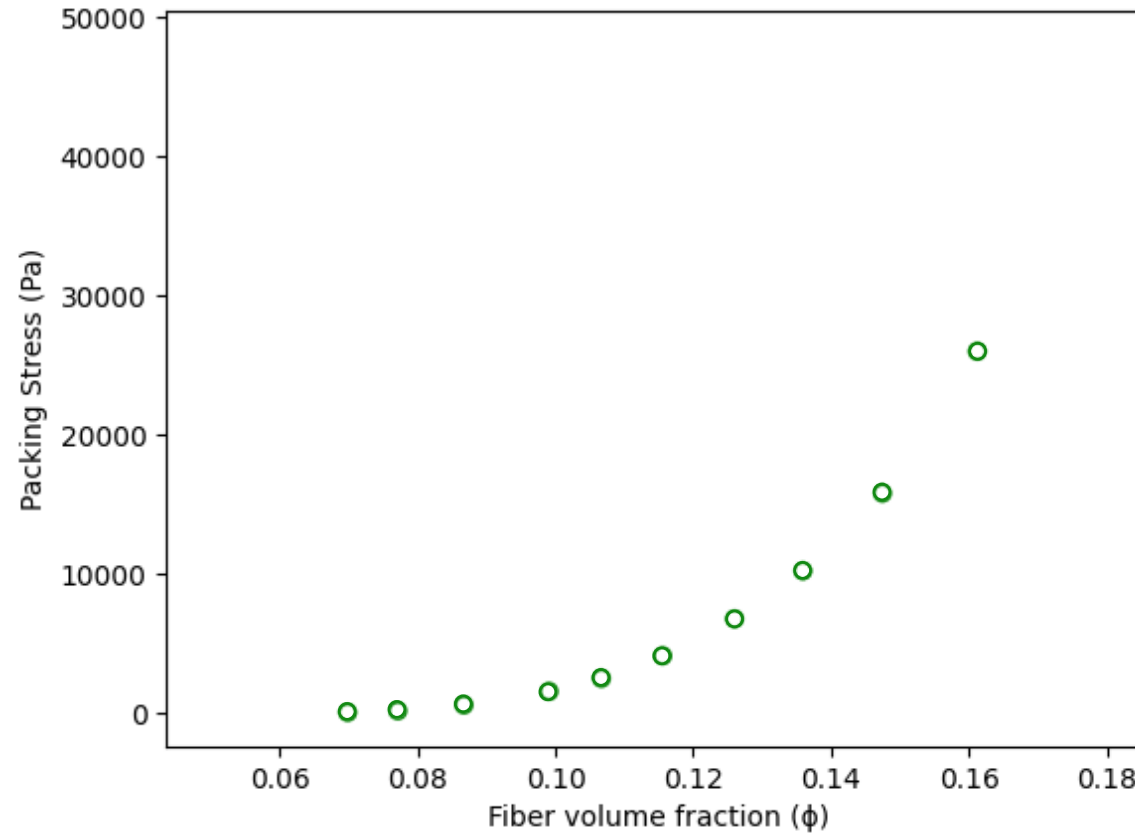

$$\phi = \frac{\text{fibre volume}}{\text{specimen area} \times \text{gap}}$$

Recycled plate with 12-mm fibers (APC CPEKK)

290 mm x 90 mm x 2 mm.

Heated it up in the radiation oven at 375C for 15mins.

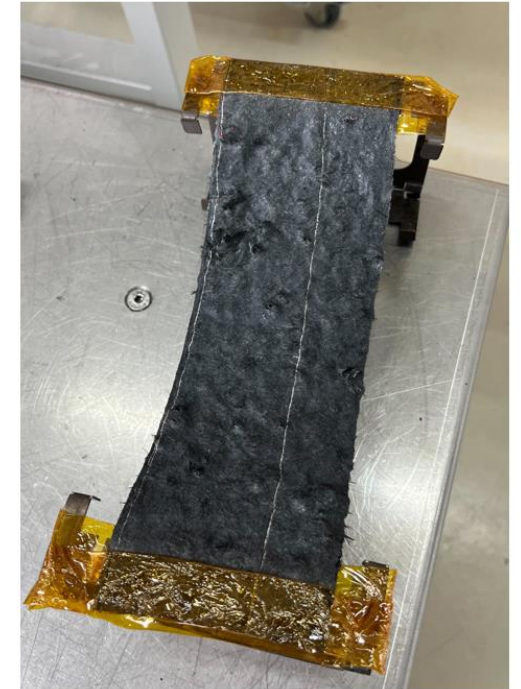
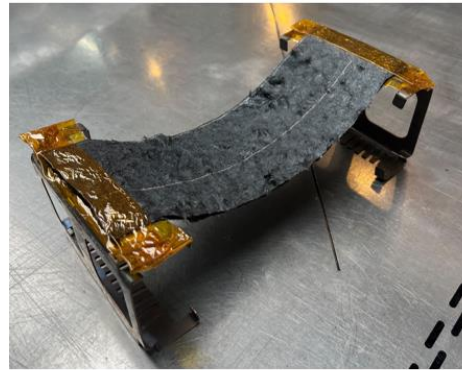
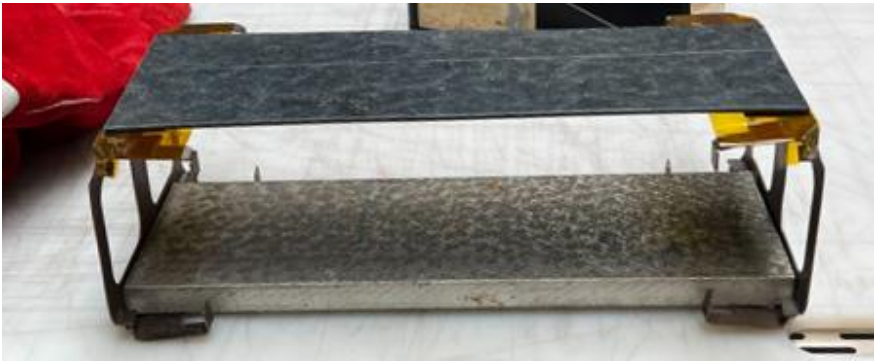

FIBER LENGTH ANALYSIS

60 mm x 20 mm machine specimen

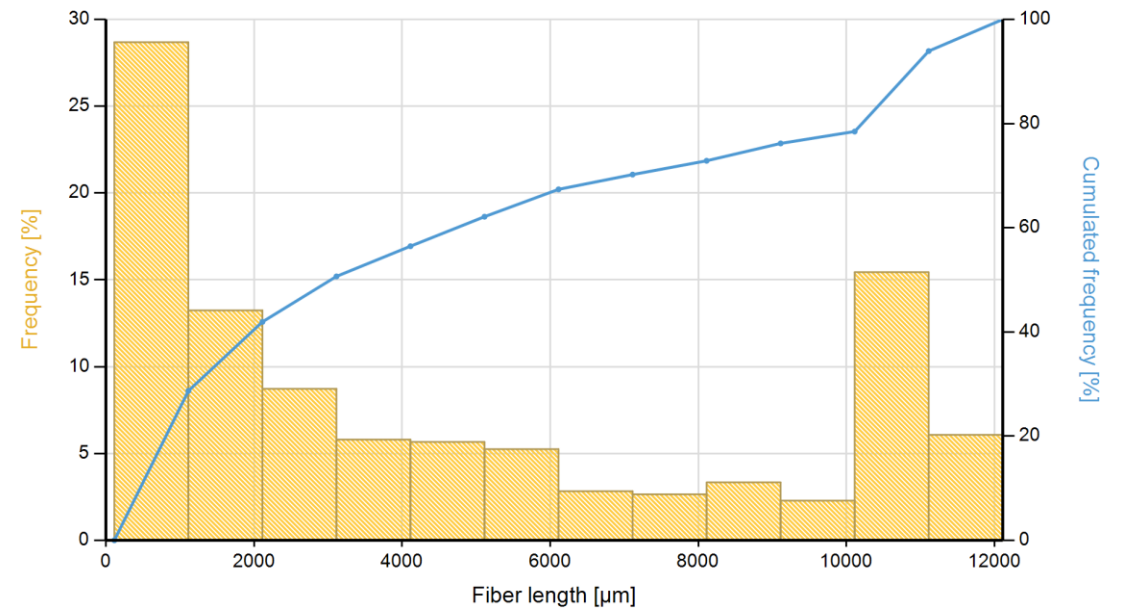
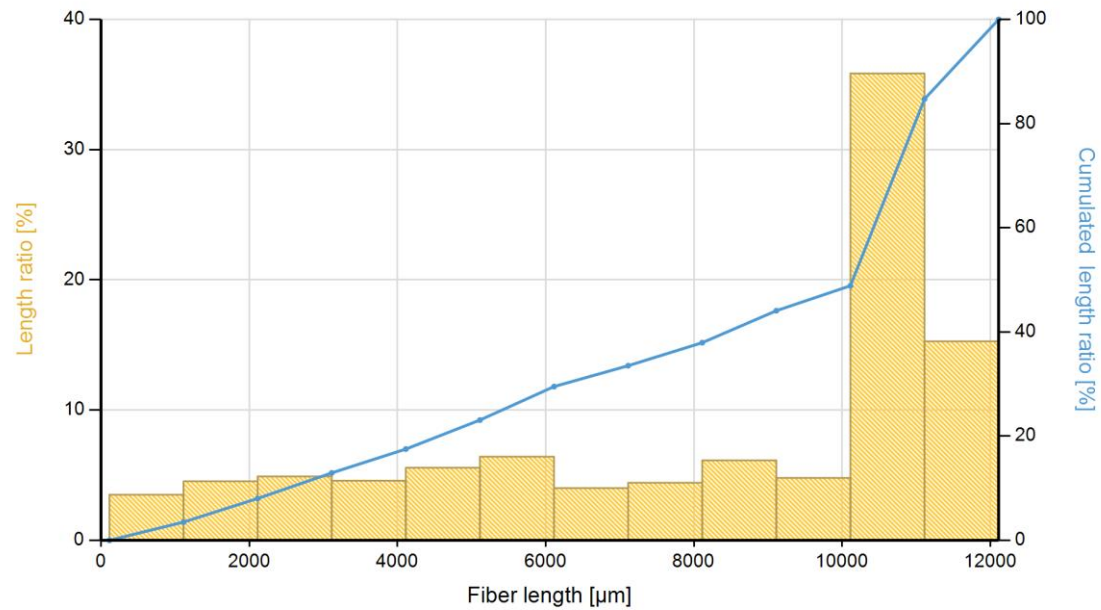

RECYCLING OF TPC LAMINATES (VINCENT, 2020)

Introduced Low-Shear Mixing

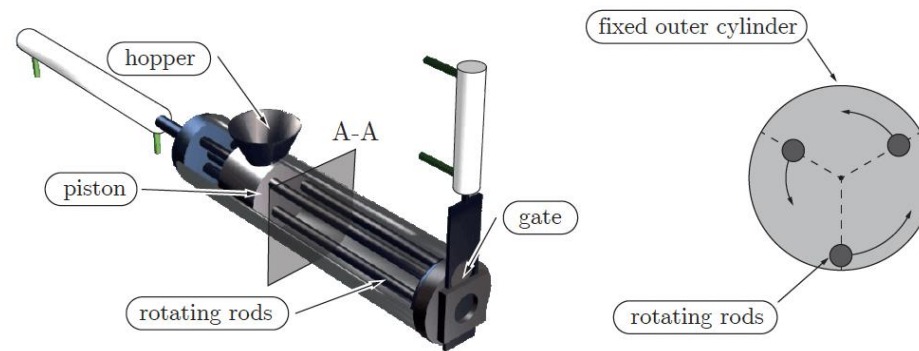
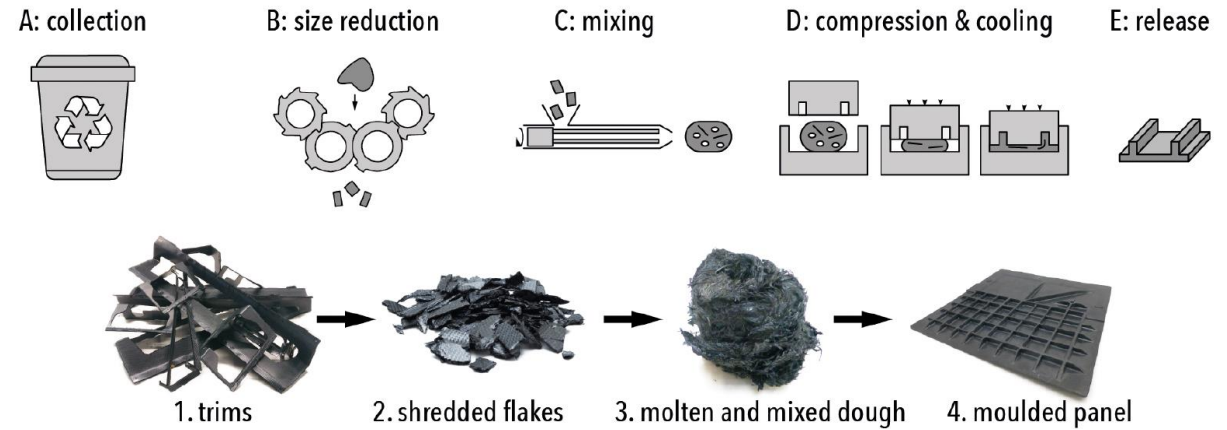
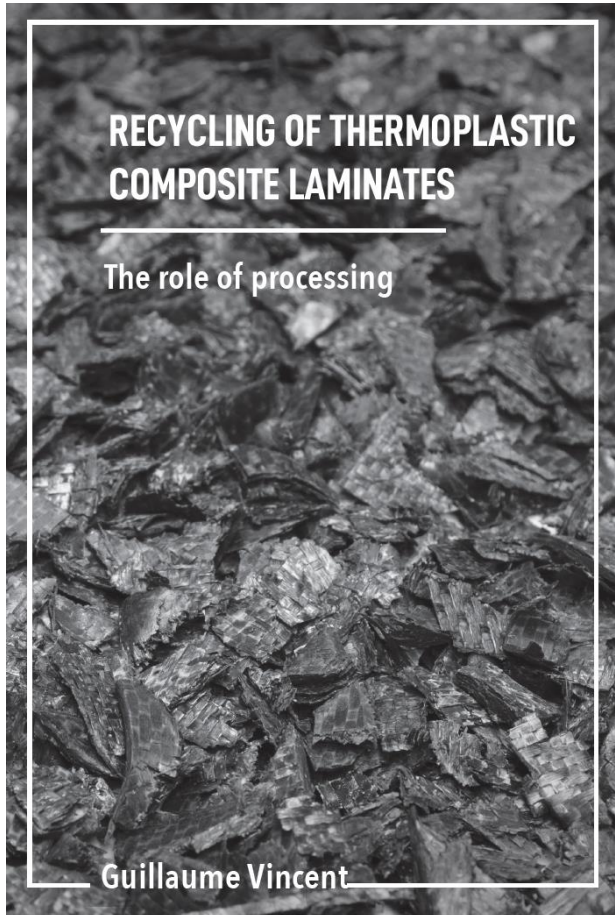

[1] G. A. Vincent. Recycling of Thermoplastic Composite Laminates: The role of processing. PhD Thesis at University of Twente, 2020.

RECYCLING OF TPC LAMINATES (VINCENT, 2020)

Macroscopic Flow Characterization

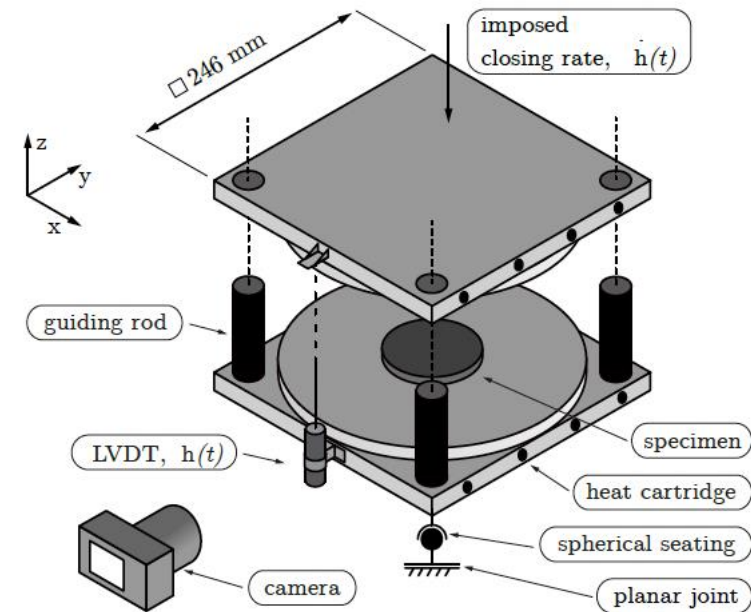
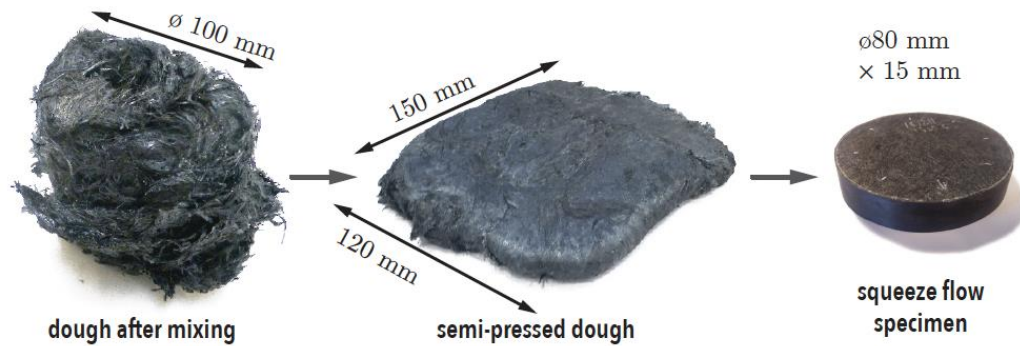

[1] G. A. Vincent. Recycling of Thermoplastic Composite Laminates: The role of processing. PhD Thesis at University of Twente, 2020.

RECYCLING OF TPC LAMINATES (VINCENT, 2020)

Challenges in Measurement: Heterogeneity

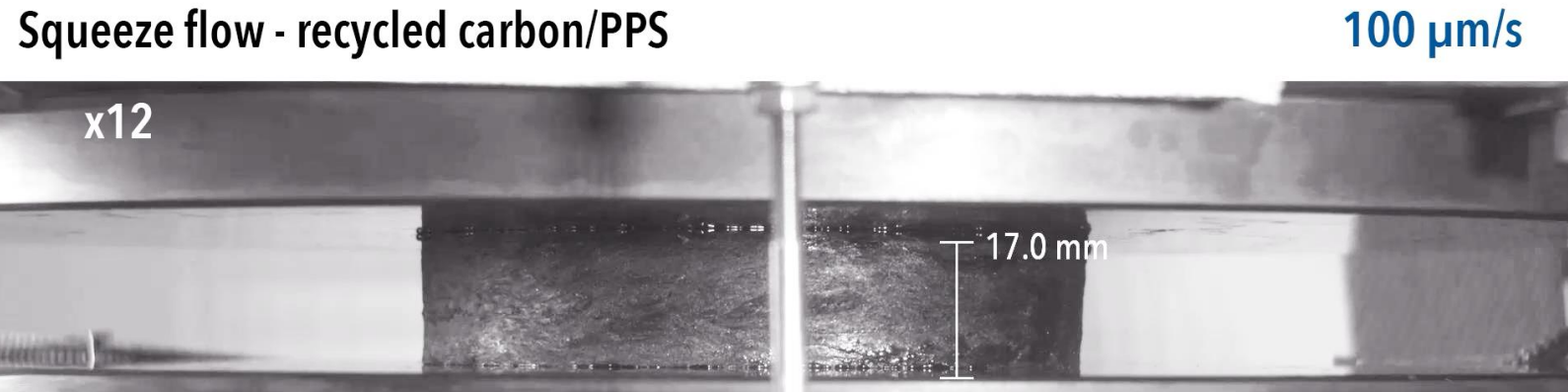

[1] G. A. Vincent. Recycling of Thermoplastic Composite Laminates: The role of processing. PhD Thesis at University of Twente, 2020.

RECYCLING OF TPC LAMINATES (VINCENT, 2020)

Challenges in Measurement: Heterogeneity

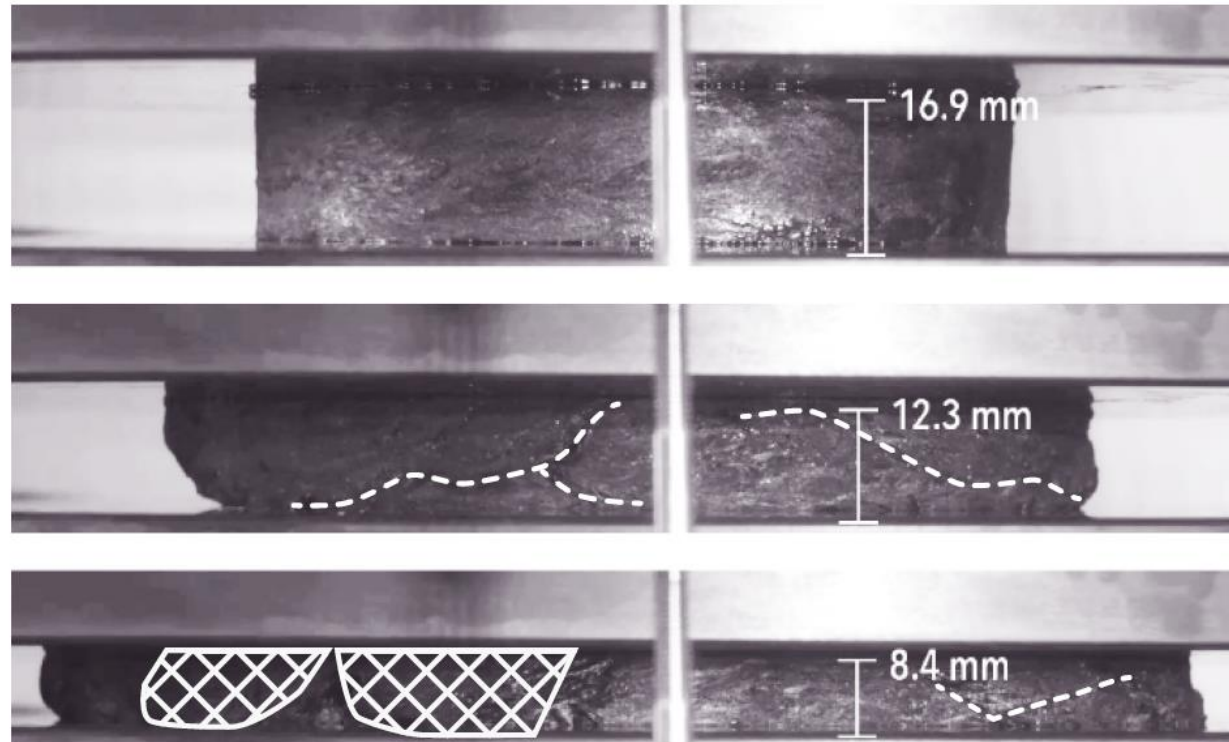

[1] G. A. Vincent. Recycling of Thermoplastic Composite Laminates: The role of processing. PhD Thesis at University of Twente, 2020.

RECYCLING OF TPC LAMINATES (VINCENT, 2020)

Challenges in Repeatability: Stochasticity

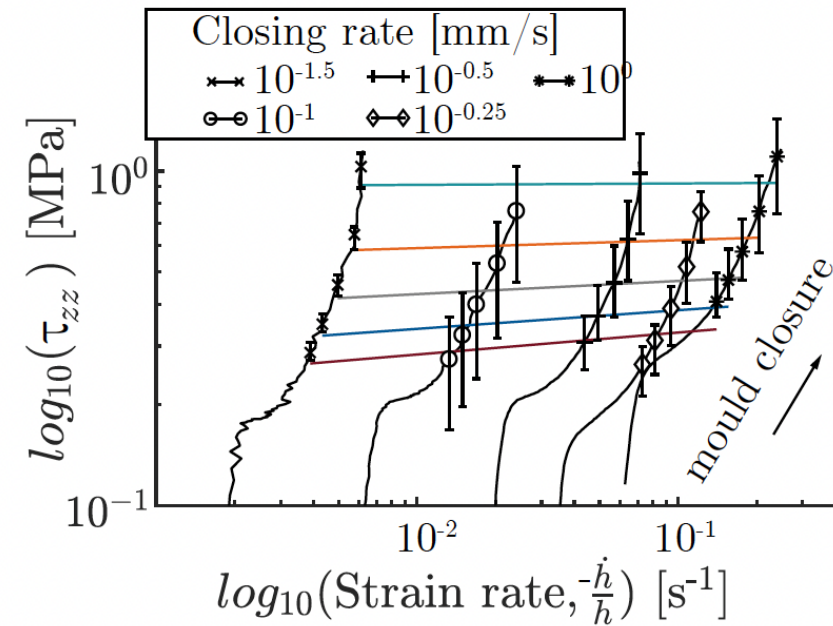
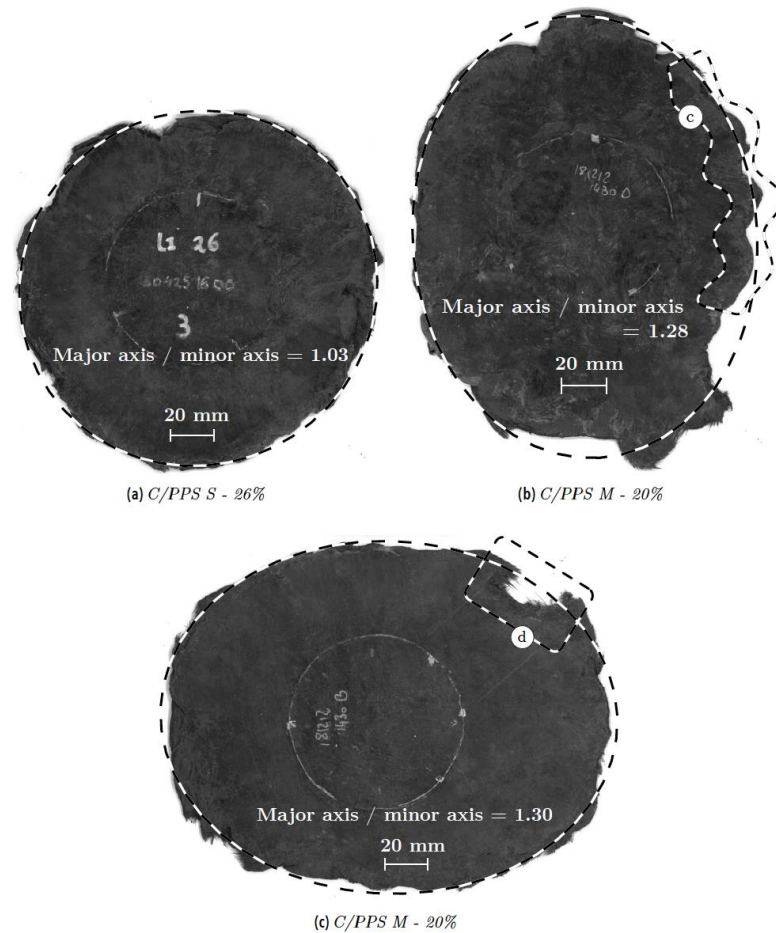

[1] G. A. Vincent. Recycling of Thermoplastic Composite Laminates: The role of processing. PhD Thesis at University of Twente, 2020.

EVALUATING QUALITY OF MIXING (VISSER, 2026)

Low-Shear Mixer 2.0: Planetary Mixer

Semi-compressed dough

